



# MODEL K-3701

## DIGITAL INDICATING CONTROLLER THERMOCOUPLE INPUT

OPERATION

AND

INSTRUCTION MANUAL



Switzer Instrument Limited

Regd. Off: 29 (Old# 14), Thanikachalam Road, P.B.No.1423, Chennai 600 017

Internet web-site  
[www.switzerinstrument.com](http://www.switzerinstrument.com)

**Sales – Head Office**

17 (Old# 9), South Boag Road, Chennai 600 017

Ph : 044-24340999 / 24343956 / 24344321

Fax : 044-24347887 e-mail : [sales@switzerinstrument.com](mailto:sales@switzerinstrument.com)

**Works**

127 Sidco Estates, Chennai 600 098

Ph : 044-26242244 / 26242255 / 26243355

Fax : 044-26248849 e-mail : [works@switzerinstrument.com](mailto:works@switzerinstrument.com)

## INTRODUCTION

Switzer K-3701 Temperature indicating controller is housed in a glass reinforced polyester enclosure suitable for weatherproof mounting. This accepts Thermocouple Type-K, T, J as input for process measurement and control.

The instrument is featured with

- 3½ digit seven segment display for displaying temperature.
- 2 control relays for on-off control with relay status indication LEDs.
- Universal SMPS for power input from 90-250VAC.
- Option of 24VDC power supply is also available.
- Optional retransmission current or voltage output.

## PRINCIPLE OF OPERATION

The instrument can be divided into various functional blocks which are

- Input signal conditioner with linearisation circuitry
- A/D converter with seven segment display drive
- Alarm and control circuitry
- Retransmission output
- Power supply

The Thermocouple input is connected to a voltage amplifier input circuit which also employs the necessary cold junction compensation. This amplifier develops a DC signal which is provided to the A/D converter which drives the seven segment display.

The alarm relay control circuitry receives the DC voltage signal for on-off control. The on-off control circuit contains the set point selection and adjustment features for setting the values between the specified instrument range.

The optional retransmission circuitry will convert the conditioned voltage to a V to I converter circuit for generating the 4-20mA output or any other customer required output which is jumper selectable.

## CONSTRUCTION

The instrument has been constructed in such a way, that the entire assembly can be removed from the enclosure by just removing 2 screws from the terminal board for changing any options through jumper selection and potentiometer adjustment. All the PCBAs are stacked together into single assembly and gets mounted and fixed to the enclosure. Refer to Figure-6.

The bottom most board contains the power supply for the entire electronics and the control relays. All terminals are located on the signal conditioner just above this power supply board. This board also contains the fuse holder. The seven segment display board is located on top of the signal conditioner board. The alarm control board is located vertically behind all the 3 boards. This board contains the relay status indicating LEDs, set point select, dead band and offset adjustment features.

The Optional retransmission board is located vertically on the left side of the assembly when viewed from front.

## INSTALLATION AND MOUNTING INSTRUCTIONS

The instrument is of surface or wall mounting type with provision of 4 mounting holes of 10 dia. each which is accessible upon removal of the cover. The cover is provided with 4 captive stainless steel screws to fix with the enclosure

base. Refer to Fig-1a and Fig-1b for details.

The 10 dia mounting holes will reduce to 6.5 dia at the bottom of the enclosure and will accommodate only 6mm screw. Recommended mounting screw: Standard M6 X 25 Ch.hd

**Fig-1a**

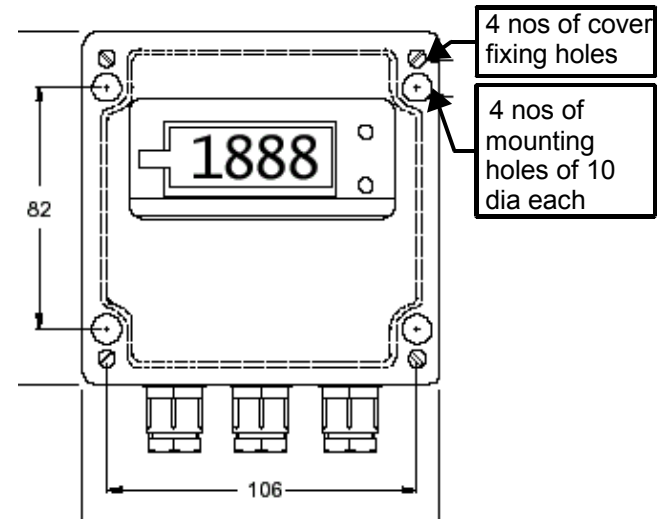

**Fig-1b**

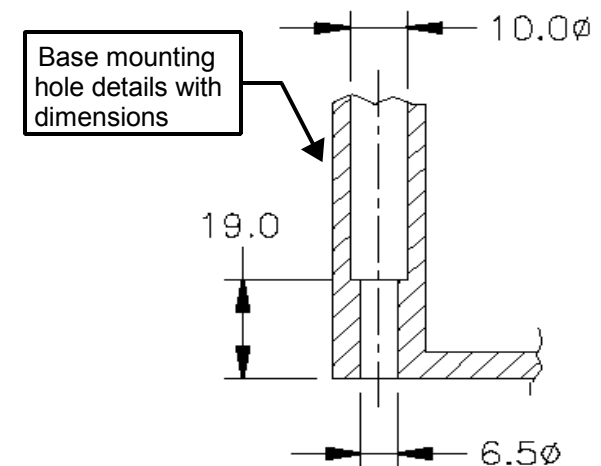

## WIRING INSTRUCTIONS

All terminals are screw clamp type suitable to accommodate 2.5mm<sup>2</sup> wires. One terminal can accommodate only one wire of indicated size and is not advisable to join more than one wire into one terminal opening.

The Thermocouple is connected to the (+) and (-) terminals located on the input board. Cold junction compensation element is located adjacent to the T/C input terminals. **DO NOT DAMAGE THE ELEMENT DURING WIRING.** Refer to Fig-2 for connection diagram.

### Caution:

- **The instrument contains hazardous voltages when powered. Hence care to be taken to ensure that the personnel who is handling this instrument do not come into contact with LIVE electrical parts. Only a competent person should handle this instrument during any kind of operation when the instrument cover is removed.**
- **Do not connect any other signal input type other**

than what is mentioned on the label of the instrument. i.e. Voltage input should not be connected to the instrument if it is calibrated for current input to avoid wrong display of reading.

Fig-2: Input terminal arrangement

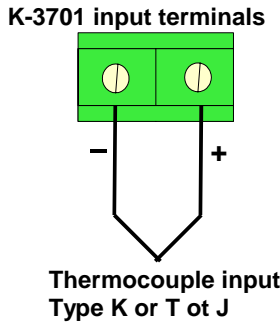

**FUSE REPLACEMENT**

The instrument is equipped with protective fuse accessible upon removal of top cover. This is located adjacent to the terminal on the terminal board. Unscrew the top cover on the fuse during any replacement and replace back with new fuse.

Recommended fuse: 500mA slow blow.

**CALIBRATION PROCEDURE**

**Equipment required:**

1. 3½ digit multimeter
2. Voltage source with mV output capability to simulate T/C voltage.

Procedure for calibration of display reading: Refer to pot locations in Figure-6.

**Display Calibration - Zero Adjustment**

1. Connect appropriate power supply to the power terminals.
2. Connect the millivolt source to the sensor terminals of the instrument as indicated in below figure.
3. Set 000 mV in the source.
4. Adjust Zero pot for a reading of 000.

Fig-3: Connection drawing

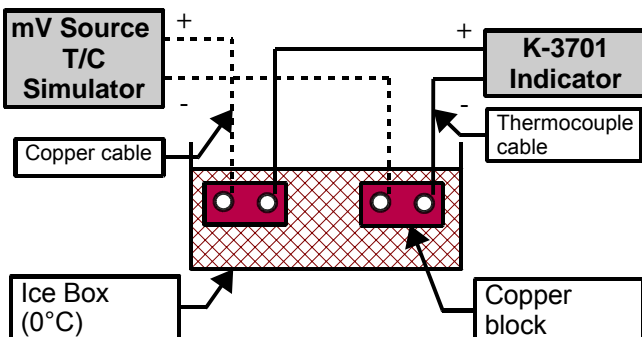

**Display Calibration - Span Adjustment**

Refer Table-1 below. Select required thermocouple, its span and display values.

1. Provide the appropriate mV for the applicable thermocouple.
2. Adjust Span pot till display is equal to the reading as in Table-1.
3. Check intermediate values.
4. This completes calibration.

Table-1: Range, Accuracy, Input value table

T/C	Range in °C	Accuracy	Span	
			Input (mV)	Display (°C)
K	(-) 50 to 1200	±0.2% of rdg ±0.5°C	48.828	1198
T	(-) 50 to 400	±0.3% of rdg ±0.5°C	20.869	398
J	(-) 50 to 700	±0.3% of rdg ±0.5°C	39.130	698

**ALARM SETTINGS**

The instrument contains provision for having 2 set point with On-Off control relays. The below procedure details the Set point and dead band adjustments for both relays. The location of potentiometer, set point switch, jumper for relay selection and relay status LEDs are located in the control board behind all the PCBA and fixed vertically.

Both set points can be configured to operate as High and Very High (or) Low and Very Low (or) High and Low types of alarms. Any setpoint can be configured in any form either as HIGH or LOW. NORMAL or INVERTED mode of relay operation is selectable for both set points.

**Set point Display:** Refer to Fig-6

Press the individual set point selection switch to read the set point value, accessible upon removal of the top cover.

Table-2: Set point selection table

Set point Switch-1	Set point Switch-2	Displayed Value
Pressed	Pressed	Process Value
Released	Pressed	Set point 1
Pressed	Released	Set point 2
Released	Released	Set point 2

**Set point adjustment:** Refer to Fig-6

Set point potentiometers are located adjacent to the set point switches and accessible upon removal of the top cover. Clockwise rotation increases the set point value on display. Counter clockwise rotation decreases the set point value on display.

**Relay mode selection:** Refer to Fig-7, 8, 9 & 10

For relay mode selection, alarm mode selection, dead band and offset adjustment, the instrument PCB assembly should be removed and taken out of the enclosure, as these components are located on the side of the PCBA. Follow these procedures to access these components for adjustment.

- Unscrew the 2 diagonally located PCB assembly fixing screws as shown in Figure-1.
- Remove the full PCB assembly from enclosure.
- Establish the necessary wiring connection related to Input and Power Supply.

Relay operation can be selected as NORMAL or INVERTED mode using Jumpers H2 and H5.

**NORMAL Mode:** Relay energizes when PV crosses the set point. Relay is OFF under normal process condition.

**INVERTED Mode:** Relay de-energizes when PV crosses the set point. Relay is ON under normal process condition.

**Unless otherwise specified, relays are set at factory in the NORMAL mode.**

**Relay and Jumper status table for alarm modes:** Refer to Fig-7, 8, 9 & 10

The following tables illustrates the selection of various modes with the jumpers H1, H2 for Set point-1 and H4, H5 for Set point-2.

**Low alarm – Set jumper H1, H4 at position 'L'**

Signal Status	Relay operating mode - Jumper H2, H5 position	
	1 – NORMAL mode	2 – INVERTED mode
PV > SP (Normal process condition)	Relay OFF	Relay ON
PV < SP (Abnormal process condition)	Relay ON	Relay OFF

**High alarm – Set jumper H1, H4 at position 'H'**

Signal Status	Relay operating mode - Jumper H2, H5 position	
	1 – INVERTED mode	2 – NORMAL mode
PV < SP (Normal process condition)	Relay ON	Relay OFF
PV > SP (Abnormal process condition)	Relay OFF	Relay ON

**Dead band and offset adjustment:** Refer to Fig-8, 9 & 10

The dead band potentiometer is located on the side of the instrument and the offset potentiometer is located on the center of Alarm control board. To access these pots the entire assembly need to be removed from the enclosure. Note that, there is no necessity to dismantle the individual PCBs and all PCBs can be connected and fixed together for these adjustments. Follow the below procedure for dead band and offset adjustment.

**(a) Low alarm**

1. Set the required set point value by adjusting the set point potentiometer.
2. Turn dead band pot fully counterclockwise. (minimum Dead band).
3. Turn offset pot fully counterclockwise.
4. Set PV equal to the set point value.
5. Trim offset pot till the relay just actuates.
6. Turn the dead band pot fully clockwise (max dead band).
7. Increase the PV for the required dead band.
8. Turn the dead band pot counterclockwise, till the relay re actuates.
9. Repeat steps 2 to 7, trim if necessary.

**(b) High alarm**

1. Set the required set point value by adjusting the set point potentiometer.
2. Turn dead band pot fully counterclockwise. (minimum Dead band).
3. Turn offset pot fully counterclockwise.
4. Set PV equal to the set point value.
5. Trim offset pot till the relay just actuates.
6. Turn the dead band pot fully clockwise (max dead band).
7. Decrease the PV for the required dead band.
8. Turn the dead band pot counterclockwise, till the relay re actuates.
9. Repeat steps 2 to 7, trim if necessary.

## ANALOG OUTPUT CALIBRATION

Refer to Fig-4 below. Analog output is provided as an option in this instrument, if the option is indicated during the time of ordering. This feature is provided as an optional PCB fixed on the left side of the whole assembly. The output form is either of CURRENT or VOLTAGE and one output is provided in an instrument. The 2 left extreme terminals are for output customer connection. Following are the types of output that is possible

- Current: 4-20mA (or) 0-20mA DC
- Voltage: 1-5V (or) 0-5V (or) 0-10V DC

Every instrument is shipped from factory pre-calibrated to the required range as ordered by the user. Recalibration is normally not required and the instrument can be put into use upon receipt. Following procedure may be followed if any calibration is required to be made. As an example, 4-20mA analog output is described here. Similar procedure will hold good for any other output.

1. Apply low range input corresponding to the minimum value of analog output which is 4mA.
2. Adjust ZERO pot for the current meter to read 4.00mA.
3. Apply high range input corresponding to the maximum value of analog output which is 20mA.
4. Adjust COARSE SPAN pot for the current meter to read a value near 20mA.
5. Adjust FINE SPAN pot for the current meter to read 20.00mA or 19.99mA depending on the capability of the current meter.
6. Check for linearity at intermediate input values.

**Fig-4**

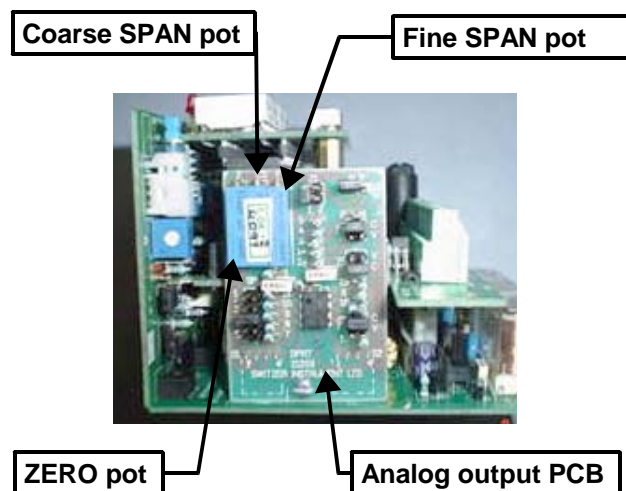

More figures are provided in the next few pages for clear illustration.

**Fig-5: Wiring Drawing**

The terminals are located on the terminal/signal board which is represented here below.

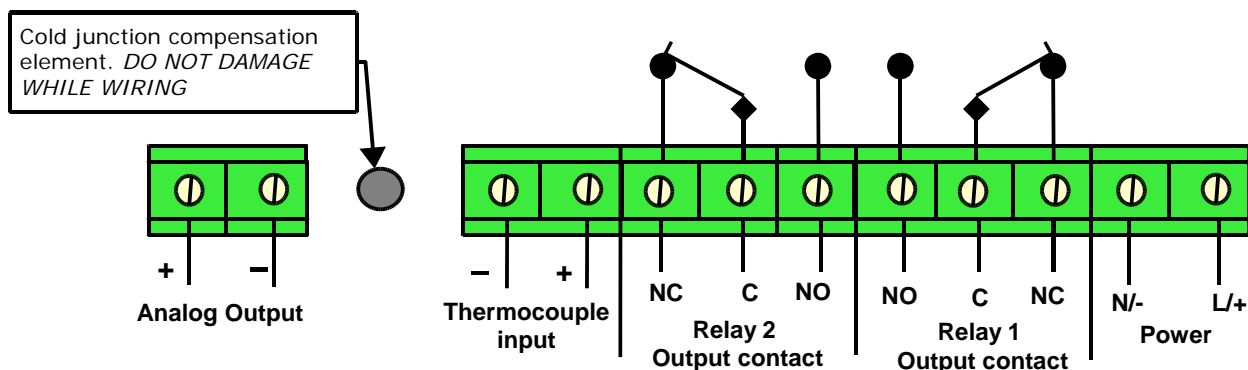

**Fig-6: Instrument top view**

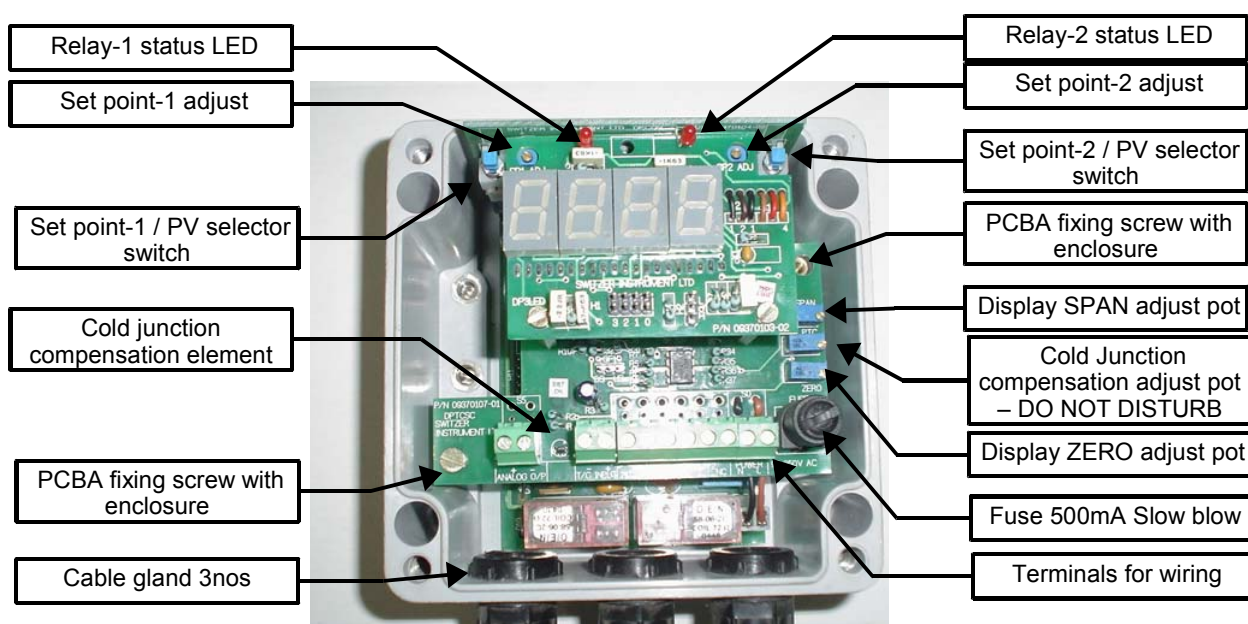

**Fig-7: Instrument right side view**

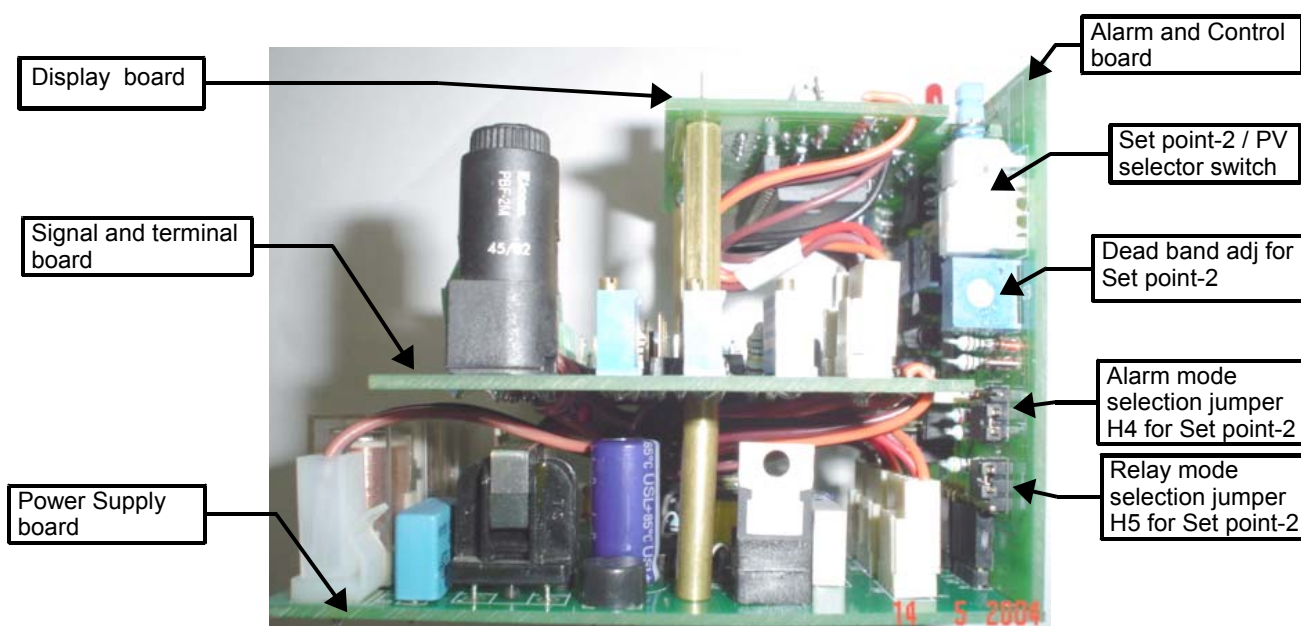

**Fig-8: Instrument Left side view**

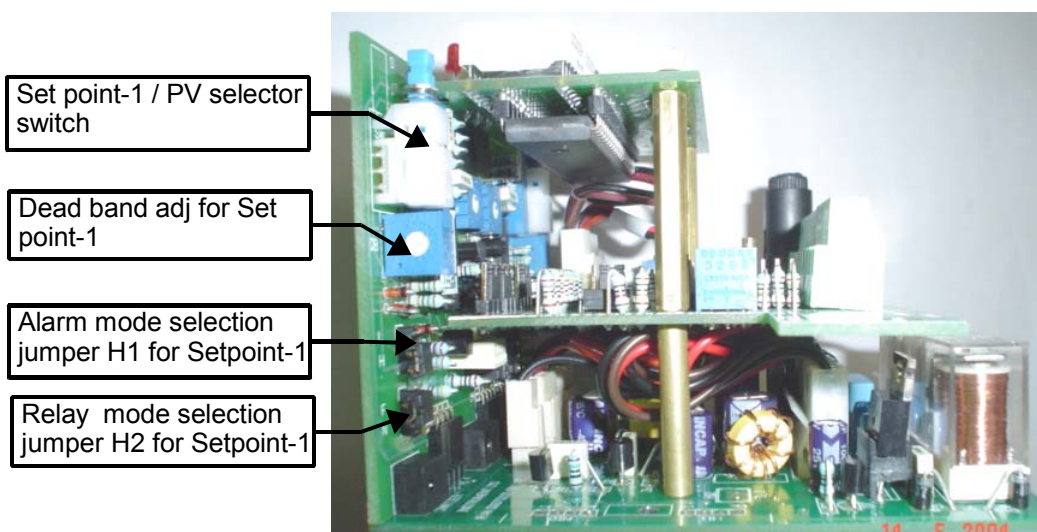

**Fig-9: Alarm and control for Offset pot location**

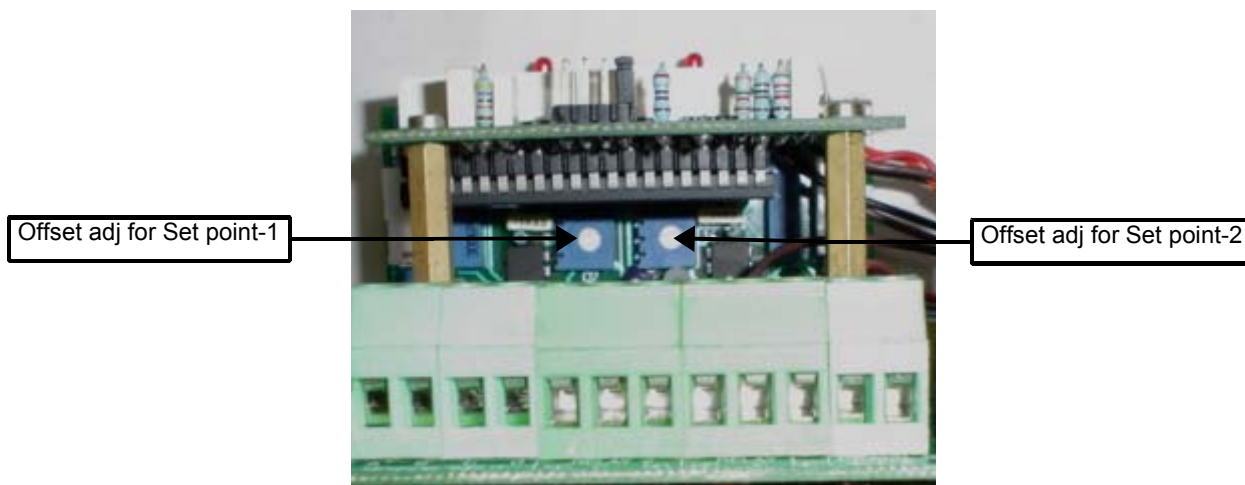

**Fig-10: Alarm and Relay mode jumper details**

Below are the selection jumpers on Alarm and Control board of both Set point-1 and 2 when viewed from front.

**Fig-10a**

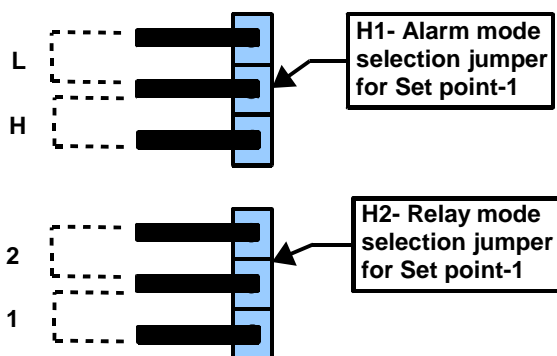

**Fig-10b**

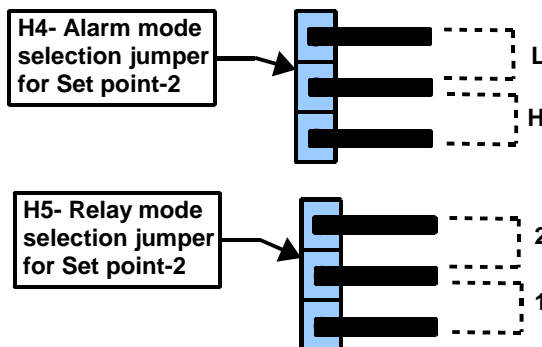

**Fig-10c**

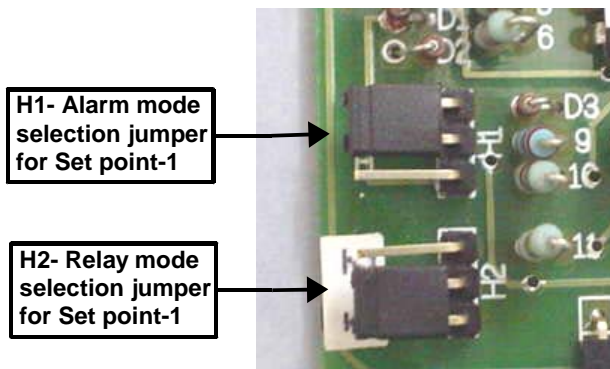

**Fig-10d**

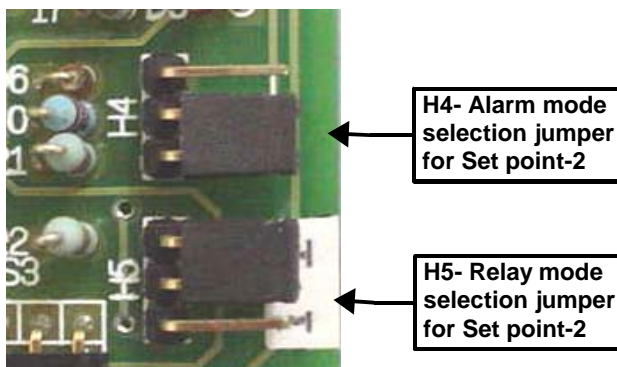

**Fig-11: OVERALL MOUNTING DIMENSIONS**

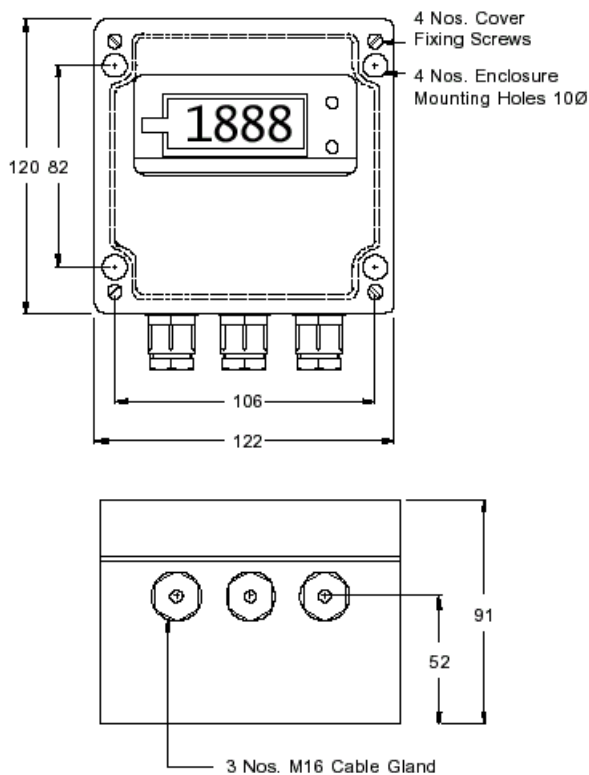

**TECHNICAL SPECIFICATIONS**

Input type	Thermocouple input, Type – K, J, T
Range	Type K: (-)50 to 1200°C Type J: (-)50 to 700°C Type T: (-)50 to 400°C
Accuracy	Type K: ± 0.2% of reading ± 0.5°C Type J: ± 0.3% of reading ± 0.5°C Type T: ± 0.3% of reading ± 0.5°C
Resolution	1°C
Display	(a) 3½ digit, seven segment LED, 14.2mm; (b) 3½ digit, seven segment LCD, 12.7mm;
Power supply	(a) 90 to 250V AC; (b) 100 to 300VDC; (c) 18 to 32VDC
Relay Output	Contact rating: 5A at 230VAC/28VDC (Res)  (a) For 1 set point – Either one of below is possible (i) SPDT change over contact (ii) DPDT change over contact  (b) For 2 set point – Each set point shall be SPDT change over contact
Deadband adjustment	Adjustable dead band of 20 counts maximum
Power	7VA max
Analog Output (optional)	Either one of below output.  (a) Current: 4-20mA, 0-20mA. Maximum load of 750Ω for current output.  (b) Voltage: 1-5VDC, 0-10VDC. Maximum load of 10mA can be sourced.
Electrical entry	M16 x 3; PVC cable gland fitted on instrument
Wiring	Through screw terminals with cage clamp feature
Ambient	Temperature – 0 to 50°C; Humidity – 95% non condensing
Enclosure	Glass reinforced polyester enclosure weatherproof to IP:65
Mounting	Wall or surface mounting
Overall dimension	122 x 120 x 91mm