



# MODEL K-3701

## TEMPERATURE INDICATING CONTROLLER Pt-100 INPUT

OPERATION

AND

INSTRUCTION MANUAL



**Switzer Instrument Limited**

Regd. Off: 29 (Old# 14), Thanikachalam Road, P.B.No.1423, Chennai 600 017

Internet web-site  
[www.switzerinstrument.com](http://www.switzerinstrument.com)

**Sales – Head Office**

17 (Old# 9), South Boag Road, Chennai 600 017

Ph : 044-24340999 / 24343956 / 24344321

Fax : 044-24347887 e-mail : [sales@switzerinstrument.com](mailto:sales@switzerinstrument.com)

**Works**

127 Sidco Estates, Chennai 600 098

Ph : 044-26242244 / 26242255 / 26243355

Fax : 044-26248849 e-mail : [works@switzerinstrument.com](mailto:works@switzerinstrument.com)

## INTRODUCTION

Switzer K-3701 Temperature indicating controller is housed in a glass reinforced polyester enclosure suitable for weatherproof mounting. This accepts RTD Pt-100 sensor with 4 or 3 wires as input for temperature measurement and control.

The instrument is featured with

- 3½ digit seven segment display for displaying temperature.
- 2 control relays for on-off control with relay status indication LEDs.
- Universal SMPS for power input from 90-250VAC.
- Optional retransmission current or voltage output.

## PRINCIPLE OF OPERATION

The instrument can be divided into various functional blocks which are

- Input signal conditioner with linearisation circuitry
- A/D converter with seven segment display drive
- Alarm and control circuitry
- Retransmission output
- Power supply

The RTD sensing element is connected as resistance input which is excited with a current of 4mA. The voltage developed across the RTD element is linearized and provided to the A/D converter which drives the seven segment display.

The alarm relay control circuitry receives the DC voltage signal for on-off control. The on-off control circuit contains the set point selection and adjustment features for setting the values between the specified instrument range.

The optional retransmission circuitry will convert the conditioned voltage to a V to I converter circuit for generating the 4-20mA output or any other customer required output which is jumper selectable.

## CONSTRUCTION

The instrument has been constructed in such a way, that the entire assembly can be removed from the enclosure by just removing 2 screws from the terminal board for changing any options through jumper selection and potentiometer adjustment. All the PCBAs are stacked together into single assembly and gets mounted and fixed to the enclosure. Refer to Figure-1.

The bottom most board contains the power supply for the entire electronics and the control relays. All terminals are located on the signal conditioner just above this power supply board. This board also contains the fuse holder. The seven segment display board is located on top of the signal conditioner board. The alarm control board is located vertically behind all the 3 boards. This board contains the relay status indicating LEDs, set point select, dead band and offset adjustment features.

The Optional retransmission board is located vertically on the left side of the assembly when viewed from front.

## INSTALLATION AND MOUNTING INSTRUCTIONS

The instrument is of surface or wall mounting type with provision of 4 mounting holes of 10 dia. each which is accessible upon removal of the cover. The cover is provided with 4 captive stainless steel screws to fix with the enclosure base. Refer to Fig-1a and Fig-1b for details.

The 10 dia mounting holes will reduce to 6.5 dia at the bottom of the enclosure and will accommodate only 6mm screw. Recommended mounting screw: Standard M6 X 25 Ch.hd

**Fig-1a**

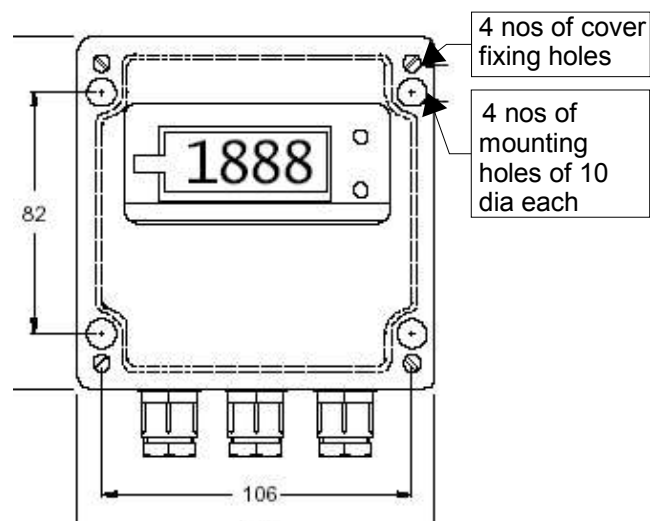

**Fig-1b**

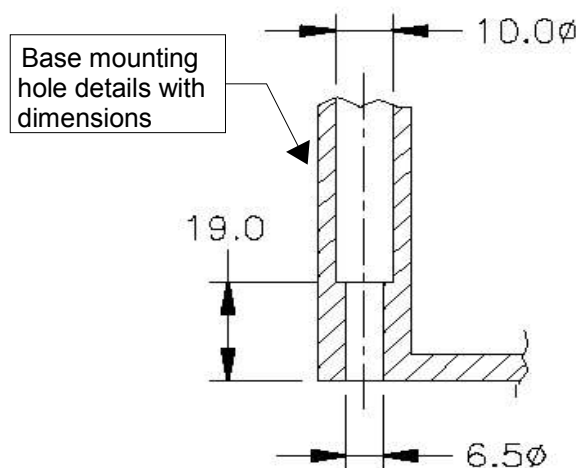

## WIRING INSTRUCTIONS

All terminals are screw clamp type suitable to accommodate 2.5mm<sup>2</sup> wires. One terminal can accommodate only one wire of indicated size and is not advisable to join more than one wire into one terminal opening.

### Note on 3 / 4 wire RTD inputs

The indicator is factory calibrated to accept 4 wire RTD Pt-100 sensors as a standard configuration. If the sensor is of 3 wire type, then the instrument need to be connected with 3 wire RTD at appropriate sensor input terminals. See Fig-2a & Fig-2b for connection method for 3 or 4 wire RTDs.

**4-wire connection:** Connect the 4 individual wires from RTD to each sensor input terminal. The total cable resistance in each wire can be upto 200Ω.

**3-wire connection:** Connect the 3 individual wires from RTD to B,C,D terminals. Terminal A and B are to be shorted together with external wire. The total cable resistance in each wire can be upto 15Ω. ZERO correction will be required after connecting the sensor input. There are 2 ways by which this ZERO correction can be performed.

**(a) Correction with Ice:**

- Connect the 3-wire RTD to appropriate terminals.
- Place the RTD in Ice bath which should be at 0°C.
- Power up the instrument. The instrument will not display 0°C, instead will be displaying a positive value.
- Adjust ZERO pot on Signal/Terminal board for the display to read 0°C

**(b) Correction with 100Ω resistor.**

- Connect the 3-wires without RTD to appropriate terminals.
- Connect a 100Ω resistor, at the sensor end of wire, in place of RTD.
- Power up the instrument. The instrument will not display 0°C, instead will be displaying a positive value.
- Adjust ZERO pot on Signal/Terminal board for the display to read 0°C.

for a reading of 000 on display for 1°C resolution or 00.0 for 0.1°C resolution.

*For SPAN adjustment with 0.1°C resolution (Range: -150.0°C to +199.9°C)*

- Set 170.31Ω corresponding to 185°C in the decade resistance box.
- Adjust SPAN pot for a reading of 185.0°C on display.

*For SPAN adjustment with 1°C resolution (Range: -150°C to +750°C)*

- Set 360.50 Ω corresponding to 750°C in the decade resistance box.
- Adjust SPAN pot for a reading of 748°C on display.

5. Recheck the zero and span values again to check for linearity. Also check at intermediate values of 25, 50, 75%.

**Fig-2a**

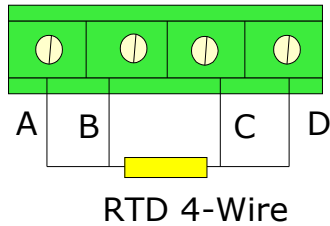

RTD 4-Wire

**Fig-2b**

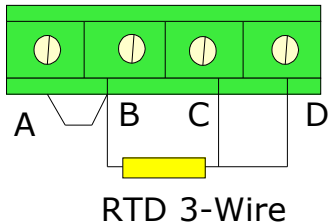

RTD 3-Wire

**Caution:**

*The instrument contains hazardous voltages when powered. Hence care to be taken to ensure that the personnel who is handling this instrument do not come into contact with LIVE electrical parts. Only a competent person should handle this instrument during any kind of operation when the instrument cover is removed.*

**FUSE REPLACEMENT**

The instrument is equipped with protective fuse accessible upon removal of top cover. This is located adjacent to the terminal on the terminal board. Unscrew the top cover on the fuse during any replacement and replace back with new fuse.

*Recommended fuse: 500mA slow blow.*

**CALIBRATION PROCEDURE**

**Equipment required:**

1. 3½ digit multimeter
2. Resistance decade box 1KΩ with an accuracy of 0.1% or better.

**Procedure for PV calibration for display reading:** Refer to pot locations in Fig-5.

1. Remove top cover.
2. Connect appropriate power supply to the power terminals.
3. Connect decade resistance box with 4 wire to sensor input terminals (for 3 wire refer to wiring drawing).
4. Set 100Ω in the decade resistance box, adjust ZERO pot

**ALARM SETTINGS**

The instrument contains provision for having 2 set point with On-Off control relays. The below procedure details the Set point and dead band adjustments for both relays. The location of potentiometer, set point switch, jumper for relay selection and relay status LEDs are located in the control board behind all the PCBA and fixed vertically.

Both set points can be configured to operate as High and Very High (or) Low and Very Low (or) High and Low types of alarms. Any setpoint can be configured in any form either as HIGH or LOW. NORMAL or INVERTED mode of relay operation is selectable for both set points.

**Set point Display:** Refer to Fig-5

Press the individual set point selection switch to read the set point value, accessible upon removal of the top cover.

*Set point selection table*

Set point Switch-1	Set point Switch-2	Displayed Value
Pressed	Pressed	Process Value
Released	Pressed	Set point 1
Pressed	Released	Set point 2
Released	Released	Set point 2

**Set point adjustment:** Refer to Fig-5

Set point potentiometers are located adjacent to the set point switches and accessible upon removal of the top cover. Clockwise rotation increases the set point value on display. Counter clockwise rotation decreases the set point value on display.

**Relay mode selection:** Refer to Fig-6,7 & 9

For relay mode selection, alarm mode selection, dead band and offset adjustment, the instrument PCB assembly should be removed and taken out of the enclosure, as these components are located on the side of the PCBA. Follow these procedures to access these components for adjustment.

- Unscrew the 2 diagonally located PCB assembly fixing screws as shown in Figure-1.
- Remove the full PCB assembly from enclosure.
- Establish the necessary wiring connection related to Input and Power Supply.

Relay operation can be selected as NORMAL or INVERTED mode using Jumpers H2 and H5.

**NORMAL Mode:** Relay energizes when PV crosses the set

point. Relay is OFF under normal process condition.

**INVERTED Mode:** Relay de-energizes when PV crosses the set point. Relay is ON under normal process condition.

**Unless otherwise specified, relays are set at factory in the NORMAL mode.**

**Relay and Jumper status table for alarm modes:** Refer to Fig-6,7 & 9

The following tables illustrates the selection of various modes with the jumpers H1, H2 for Set point-1 and H4, H5 for Set point-2.

**Low alarm – Set jumper H1, H4 at position 'L'**

Signal Status	Relay operating mode - Jumper H2, H5 position	
	1 – NORMAL mode	2 – INVERTED mode
PV > SP (Normal process condition)	Relay OFF	Relay ON
PV < SP (Abnormal process condition)	Relay ON	Relay OFF

**High alarm – Set jumper H1, H4 at position 'H'**

Signal Status	Relay operating mode - Jumper H2, H5 position	
	1 – INVERTED mode	2 – NORMAL mode
PV < SP (Normal process condition)	Relay ON	Relay OFF
PV > SP (Abnormal process condition)	Relay OFF	Relay ON

**Dead band and offset adjustment:** Refer to Fig-6,7 & 8

The dead band potentiometer is located on the side of the instrument and the offset potentiometer is located on the center of Alarm control board. To access these pots the entire assembly need to be removed from the enclosure. Note that, there is no necessity to dismantle the individual PCBs and all PCBs can be connected and fixed together for these adjustments. Follow the below procedure for dead band and offset adjustment.

#### (a) Low alarm

1. Set the required set point value by adjusting the set point potentiometer.
2. Turn dead band pot fully counterclockwise. (minimum Dead band).
3. Turn offset pot fully counterclockwise.
4. Set PV equal to the set point value.
5. Trim offset pot till the relay just actuates.
6. Turn the dead band pot fully clockwise (max dead band).
7. Increase the PV for the required dead band.
8. Turn the dead band pot counterclockwise, till the relay re actuates.
9. Repeat steps 2 to 7, trim if necessary.

#### (b) High alarm

1. Set the required set point value by adjusting the set point potentiometer.
2. Turn dead band pot fully counterclockwise. (minimum Dead band).
3. Turn offset pot fully counterclockwise.
4. Set PV equal to the set point value.
5. Trim offset pot till the relay just actuates.
6. Turn the dead band pot fully clockwise (max dead band).
7. Decrease the PV for the required dead band.

8. Turn the dead band pot counterclockwise, till the relay re actuates.
9. Repeat steps 2 to 7, trim if necessary.

**ANALOG OUTPUT CALIBRATION** See Fig-3 below.

Analog output is provided as an option in this instrument, if the option is exercised during the time of ordering. This feature is provided as an optional PCB fixed on the left side of the whole assembly. The output form is either of CURRENT or VOLTAGE and one output is provided in an instrument. The 2 left extreme terminals are for output customer connection. Following are the types of output that is possible

- Current: 4-20mA (or) 0-20mA DC
- Voltage: 1-5V (or) 0-5V (or) 0-10V DC

Every instrument is shipped from factory precalibrated to the required range as ordered by the user. Recalibration is normally not required and the instrument can be put into use upon receipt. Following procedure may be followed if any calibration is required to be made. As an example, 4-20mA analog output is described here. Similar procedure will hold good for any other output.

1. Apply low range input corresponding to the minimum value of analog output which is 4mA.
2. Adjust ZERO pot for the current meter to read 4.00mA.
3. Apply high range input corresponding to the maximum value of analog output which is 20mA.
4. Adjust COARSE SPAN pot for the current meter to read a value near 20mA.
5. Adjust FINE SPAN pot for the current meter to read 20.00mA or 19.99mA depending on the capability of the current meter.
6. Check for linearity at intermediate input values.

**Fig-3**

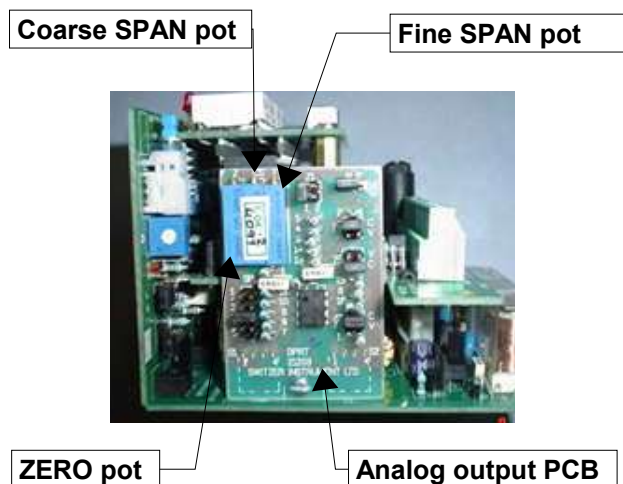

**More figures are provided in the next few pages for clear illustration.**

**Fig-4: Wiring Drawing**

The terminals are located on the terminal/signal board which is represented here below.

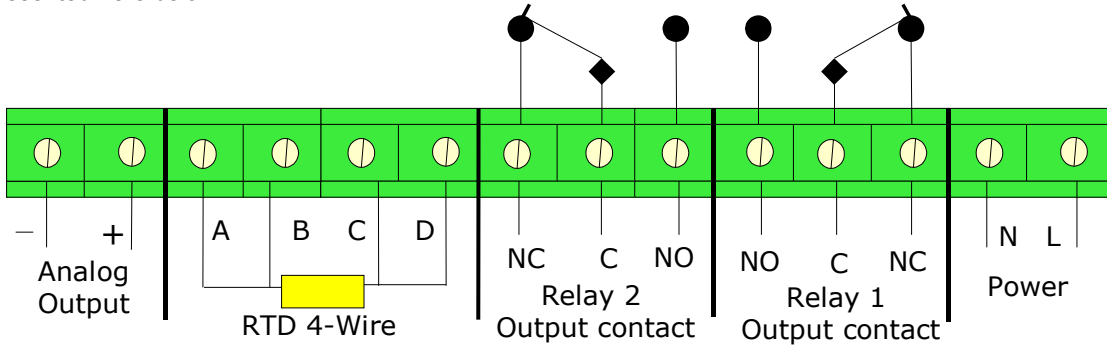

**Fig-5: Instrument top view**

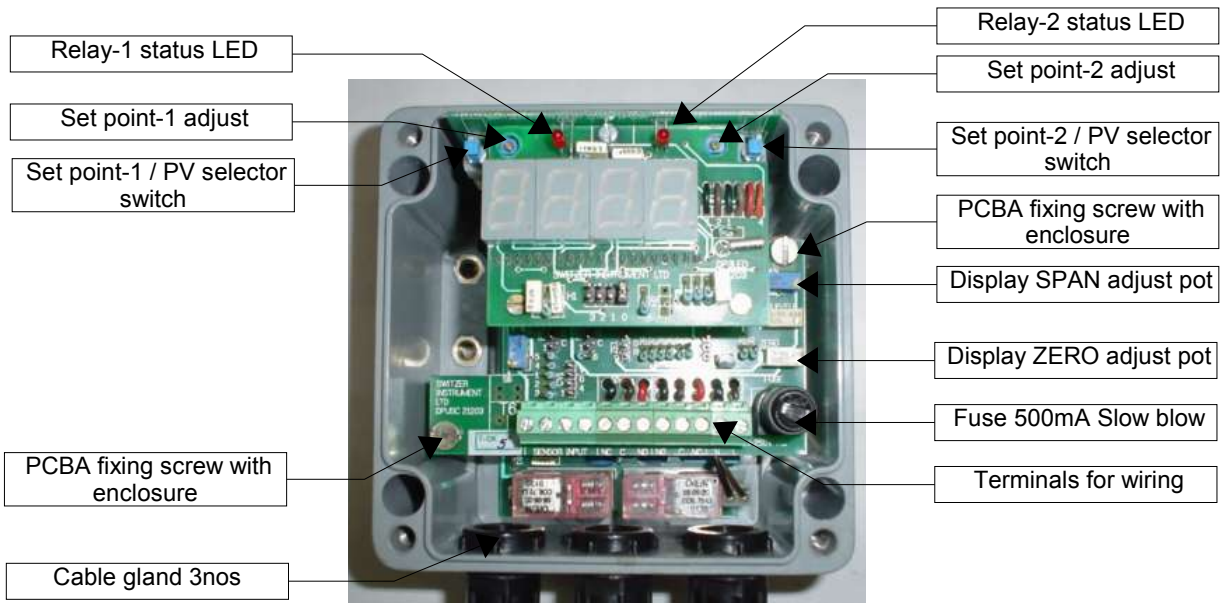

**Fig-6: Instrument right side view**

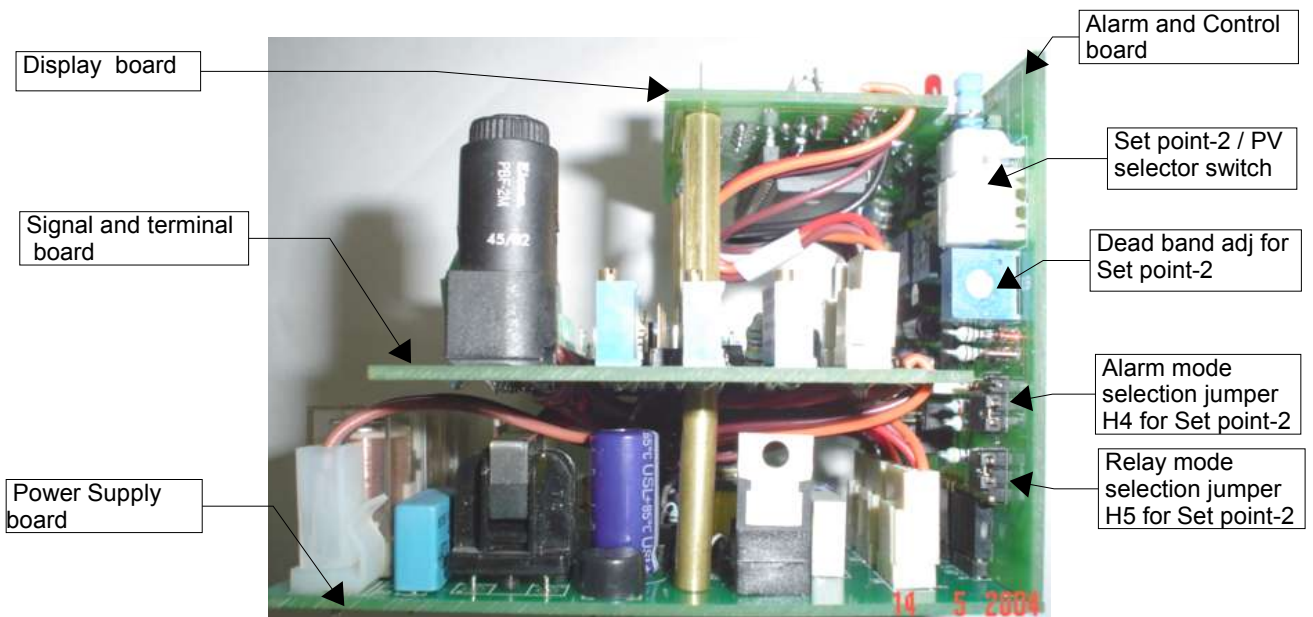

**Fig-7: Instrument Left side view**

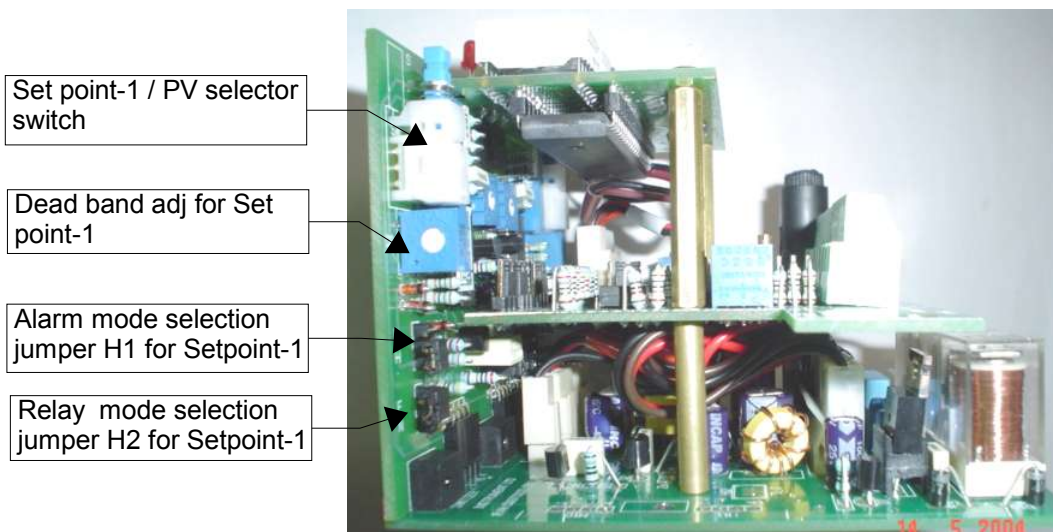

**Fig-8: Alarm and control for Offset pot location**

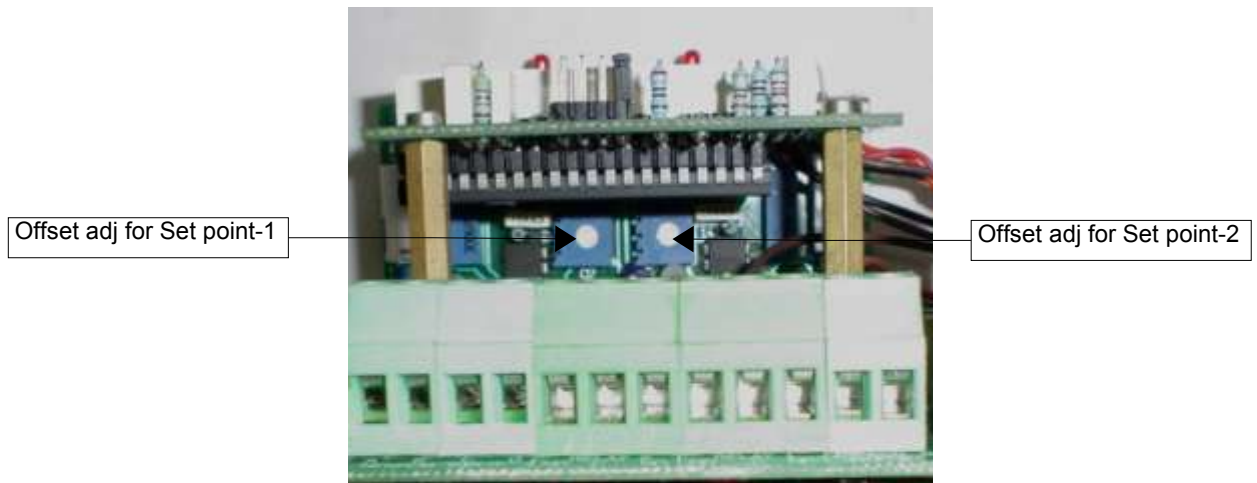

**Fig-9: Alarm and Relay mode jumper details**

Below are the selection jumpers on Alarm and Control board of both Set point-1 and 2 when viewed from front.

**Fig-9a**

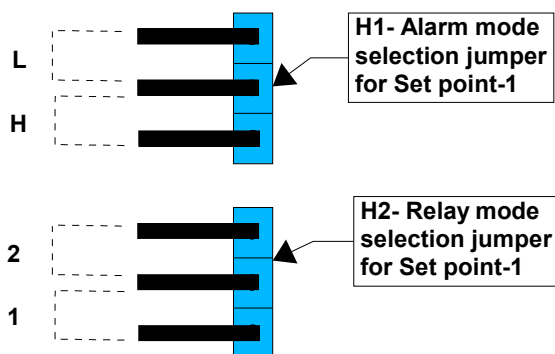

**Fig-9b**

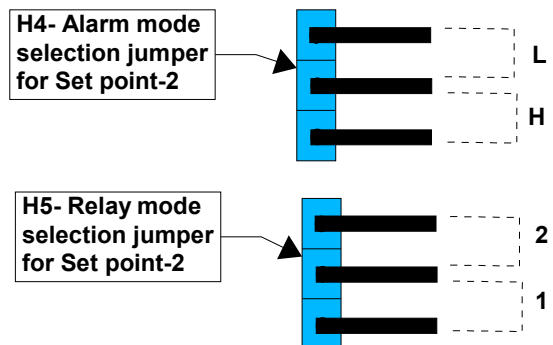

Fig-9c

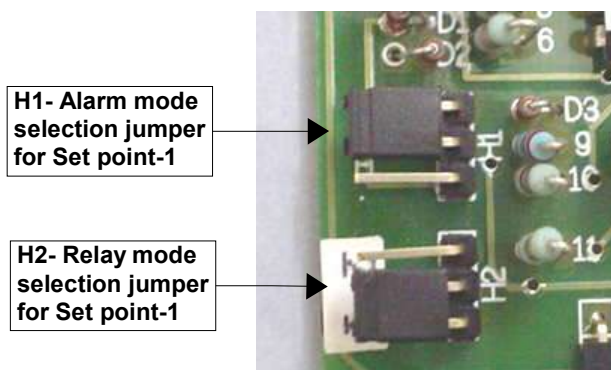

Fig-9d

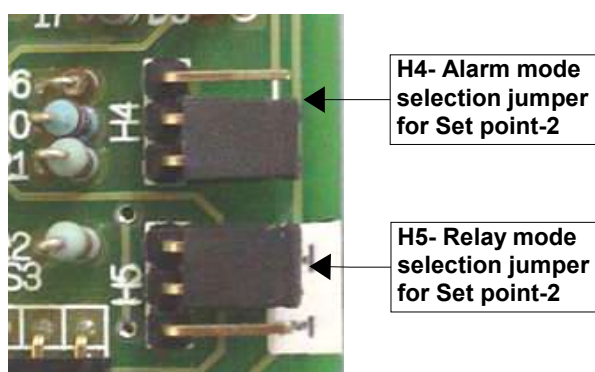
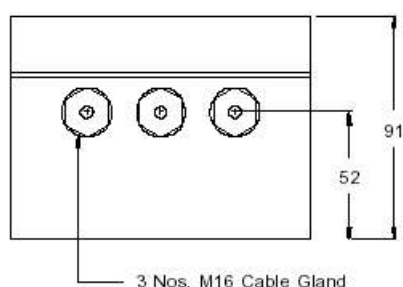
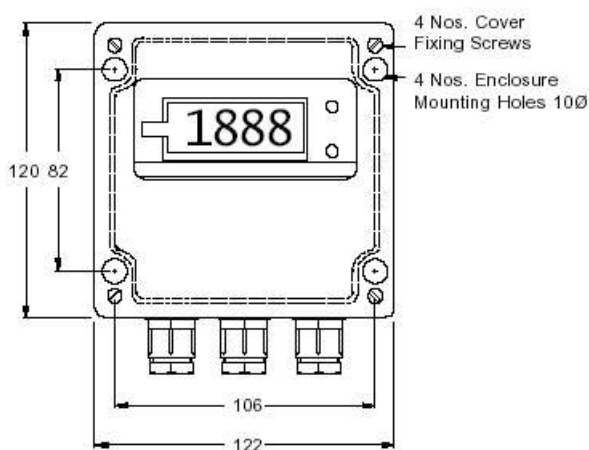

Fig-10: OVERALL MOUNTING DIMENSIONS



TECHNICAL SPECIFICATIONS

Range	(a) -100.0 to 199.9°C (b) - 150 to 750°C
Accuracy	± 0.2% of reading ± 1 digit
Resolution	0.1°C for < 200°C range 1°C for > 200°C range;
Sensor Operation mode	(a) 4 wire constant current as standard configuration; (b) 3 wire RTD with cable resistance of 15Ω max;
Display	(a) 3½ digit, seven segment LED, 14.2mm; (b) 3½ digit, seven segment LCD, 12.7mm;
Power supply	(a) 90 to 250V AC (b) 100 to 300VDC
Relay Output	(a) For 1 set point: Either one of below is possible (i) SPDT change over contact rated at 5A @ 230VAC/28VDC (Res) (ii) DPDT change over contact rated at 5A @ 230VAC/28VDC (Res)  (b) For 2 set point: Each set point relay contact shall be SPDT change over contact each rated at 5A @ 230VAC/28VDC (Res)
Dead band adjustment	Adjustable dead band of 20 counts maximum
Power consumption	7VA max
Analog Output (optional) Either one of indicated output.	Current: 4-20mA, 0-20mA  Voltage: 1-5VDC, 0-10VDC
Electrical entry	M16 x 3; PVC cable gland fitted on instrument
Wiring	Through screw terminals with cage clamp feature
Ambient	Temperature – 0 to 50°C; Humidity – 95% non condensing
Enclosure	Glass reinforced polyester enclosure weatherproof to IP:65
Mounting	Wall or surface mounting
Overall dimension	122 x 120 x 91mm