

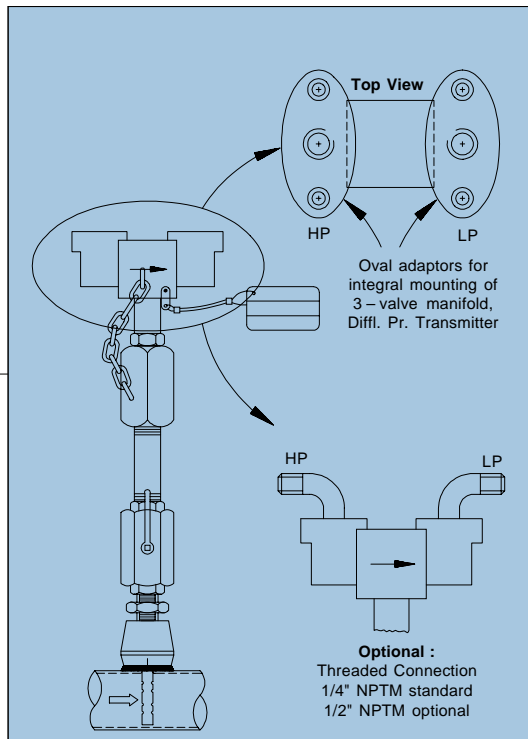

DELTA TUBE — FLOW RATE SENSOR FOR PROCESS PIPES

311 321 331
312 322 332

- GAS, LIQUID AND STEAM APPLICATIONS ● RETRACTABLE TYPE FOR INSERTION AND REMOVAL WITHOUT PROCESS SHUT DOWN ●
- LOW PERMANENT PRESSURE LOSS ● HIGH ENERGY CONSERVATION ●



MODELS 311 & 312

The Delta tube® is a low cost, low maintenance, high accuracy flow sensor for use on steam, gas and liquid flow applications. Manufactured based on proven design of Mid-West, USA, these are rugged in construction, and simple to install. The flow sensor is a multi-ported averaging pitot tube which spans the entire flow profile and produces differential pressure which has square root relationship with flow rate. Based on pipe or duct size the Delta tube is constructed so that strategically located sensing ports continually sample the impact and static pressures produced by the Delta tube's obstruction of the flow stream profile. Within the probe the impact pressures sensed by the upstream are continually averaged in an isolated plenum chamber. Similarly the static pressures sensed by the downstream ports are averaged in a second isolated plenum chamber.

All conventional secondary instruments can be used for direct measurement, or transmission of the differential pressure produced by the Delta tube which is proportional to square of flow rate.

The models 311, 312, 321, 322, 331 & 332 are wet tap type with insert-retract facility having threaded ball valves and threaded fittings so that it can be directly screwed on to the thread-o-let provided on the pipe. Models 311

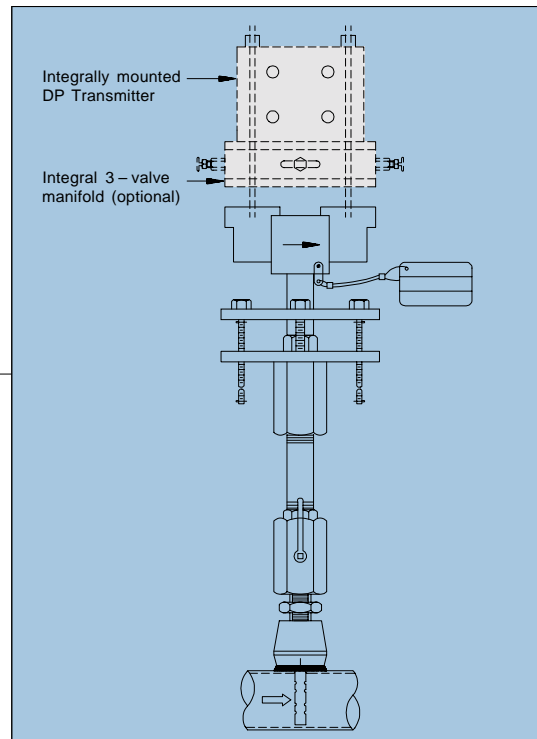

MODELS 321 & 322

and 312 are low pressure versions in which insertion and removal of probe is effected by hand and models 321, 322, 331 & 332 are high pressure versions and are provided with insert retract rods for probe insertion and removal. These models can be inserted or removed from the flow line without process shut down. The models 311, 321 & 331 are suitable for line sizes ranging from 3" to 24" while the models 312, 322, 332 are suitable for line sizes ranging from 3" to 60" as standard. For higher sizes please consult factory.

Many other versions of Delta Tubes are also available to suit various applications such as in-line series, direct insert type, duct mounted type, flange mounted type or wet tap type with flanged connection having retractable facility vide models 300, 301, 302, 307, 308, 341, 342, 343 & 323.

Delta Tubes offer excellent advantages compared to conventional primary flow elements such as — low installation cost, low permanent pressure loss and hence high energy conservation.

The process connection head of the delta tube has been designed to facilitate integral mounting of a 3-valve manifold and so the transmitter as well. Please refer schematic diagram shown above.

GENERAL SPECIFICATIONS

Basic Model No.	311 or 321 or 331 312 or 322 or 332									
Design	Mid-West, Michigan USA									
Mounting Type	Delta tap-insertion & removal with insert retract facility without process shutdown									
Probe Details										
Profile	Pear bar									
Size	1/2" nominal dia for 311, 321 & 331 1" nominal dia for 312, 322, & 332									
Material	316 SS									
Head Material	316 SS									
Pressure and Temperature Rating	<table border="0"> <tr> <td rowspan="4">}</td> <td>For models 311 & 312</td> </tr> <tr> <td>100 PSIG at 205°C</td> </tr> <tr> <td>For models 321 & 322</td> </tr> <tr> <td>1000 PSIG at 43°C</td> </tr> <tr> <td></td> <td>For models 331 & 332</td> </tr> <tr> <td></td> <td>1500 PSIG at 43°C</td> </tr> </table>	}	For models 311 & 312	100 PSIG at 205°C	For models 321 & 322	1000 PSIG at 43°C		For models 331 & 332		1500 PSIG at 43°C
}	For models 311 & 312									
	100 PSIG at 205°C									
	For models 321 & 322									
	1000 PSIG at 43°C									
	For models 331 & 332									
	1500 PSIG at 43°C									
Support	Single or Double									
Process Connection	Standard : Oval adaptors for integral mounting of 3 – valve manifold and / or Diff. Pressure Transmitter. Optional : Threaded connection 1/4" NPTM std; 1/2" NPTM optional.									

Attaching Hardware Details

For Top Support

Thread-o-let	CS or 316 SS to suit probe dia
Hex. Nipple, Extension Nipple & Packing Gland	CS or 316 SS to suit probe dia
Packing	Solid Teflon or grafoil rings or special
Insert retract Mechanism	Provided in 316 SS for 321, 322, 331 and 332. Not provided in 311 & 312 as insertion and removal to be effected by hand after loosening gland packing.

Insertion Valve Details

Type	Ball valve
Body material	316 SS or CS
Trim material	316 SS
Rating — Threaded	69 bar for SS; 100 bar for CS body
— Flanged	Limited to flange rating
Connection	3/4" NPTF for 311, 321 & 331 1 1/4" NPTF for 312, 322 & 332 3/4" ANSI 150 RF for 311S, 321S & 331S and 1 1/2" ANSI 150 RF for 312S, 322S & 332S

For Bottom Support

Thread-o-let & Pipe Plug	CS or 316 SS to suit probe dia
Accuracy	±1% of actual flow

PROBE CONSTRUCTION AND PROFILE

Flow ⇒ 	Pear Shaped Profile Delta Tube Size : 1/2" Applicable for Models : 311, 321, 331, 311 S, 321 S & 331 S
--	---

Flow ⇒ 	Pear Shaped Profile Delta Tube Size : 1" Applicable for Models : 312, 322, 332, 312 S, 322 S & 332 S
--	---

ORDERING INFORMATION

BASIC MODEL NO.	with Screwed Ballvalve	311, 321, 331, 312, 322, 332	A	G	0	0	H	A
	with Flanged Ballvalve	311 S, 321 S, 331 S, 312 S, 322 S, 332 S						
ATTACHING HARDWARE MATERIAL	Carbon Steel		A					
	All 316 Stainless Steel		B					
PIPE SIZE	3" — G	14" — N	36" — U					
	4" — H	16" — P	42" — V					
	6" — J	18" — Q	48" — W					
	8" — K	20" — R	60" — X					
	10" — L	24" — S	Special — Z					
	12" — M	30" — T						
PIPE SCHEDULE	Schedule 40					0		
	Schedule 80					1		
	All others including Cast Iron pipe, Concrete lined, Fibre glass, etc. (Customer to specify)					9		
CONSTRUCTION	Single Support							0
	Double Support							1
PROCESS PIPE ORIENTATION *	Horizontal							H
	Vertical							V
SEAL MATERIAL	Solid Teflon® (Standard)							A
	Grafoil® rings							B
	Special (Contact Factory)							Z

Note : * Generally the Probe Orientation is Vertical in the process line. If it is different, customer to specify clearly with a sketch.
For more technical information on theory, sizing, selection, installation, etc., please ask switzer brochure on "Delta Tube Flow Elements".

* Teflon® is a registered trademark of E.I.Dupont de Nemours and Company
 Grafoil® is a registered trademark of UCAR Carbon Co. Inc

Prior notification of changes in specification is impracticable due to continuous development.

FOR SWITZER'S OFFICES IN INDIA

CHECK AT:

<http://www.switzerinstrument.com/offices.htm>

Manufactured with
 Know-how from
Mid-West®
 Instrument
 MICHIGAN, USA