



TEMPERATURE SWITCHES

**WEATHERPROOF
FLAMEPROOF**

SERIES 720 / 770 : REMOTE MOUNT / SERIES 730 : DIRECT MOUNT

- **GOOD REPEATABILITY** ● **S.S. INTERNALS** ●
- **TAMPERPROOF SETPOINT ADJUSTMENT WITH LOCKING DEVICE** ●
- **RUGGED DESIGN** ●

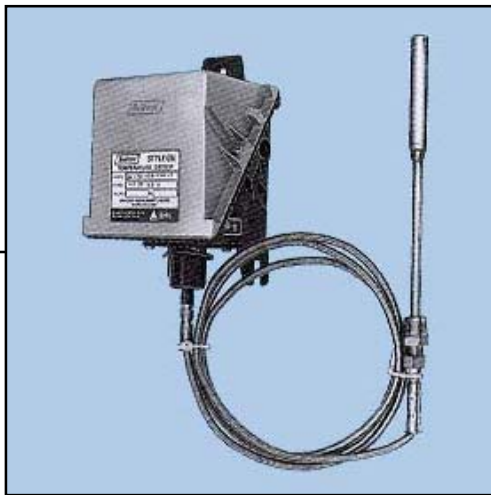

Series 720 / 770 in Style 'GM' Enclosure



Series 730 in Style 'GK' Enclosure

Switzer Series 720 / 730 vapour pressure and Series 770 gas filled Temperature Switches are devices using the time-proven mechanisms of Series 200 pressure switches.

The precision mechanisms are of stainless steel for arduous atmospheres and high humidity.

Models 721, 723, 781 and 771, 773 & 774 have capillary systems for remote sensing. Models 731, 733 & 734 have rigid-stem thermal systems.

Several convenient standard temperature ranges are available. Setpoint is continuously adjustable over the instrument range. A calibrated scale is provided for approximate switch setting.

GENERAL SPECIFICATIONS

ENCLOSURE		Scale Accuracy	± 5% FSR (Note 6)
GM	Pressure die cast Aluminium, weatherproof to IP : 66	SWITCHING	
GA	Investment cast, 316 SS weather-proof to IP:66	Element	Instrument quality SPCO (SPDT) microswitch (Note 10 & 11)
GK	Die cast Aluminium, weatherproof to IP:66 & flameproof to Gr.IIA, IIB or IIC for H ₂ gas. (Note 1)	Differential	Fixed or Wideband adjustable
Range	Several standard ranges between (-)50°C to (+)300°C	Max. Working Temp.	Refer Range Code table
Sensor	Vapour Pressure / Gas filled thermal system actuating a 316L SS Bellows	Ambient Temp.	(-)10°C to (+) 60°C (Note 12)
Wetted parts	316 SS bulb	CONNECTION	
Repeatability	+ 1% FSR (Note 4)	To Thermowell	Thru' sliding gland – 3/8" NPT(M)
		Electrical	3/4" ETF std; 1/2" NPTF optional; Dual entry optional
		Mounting	Back panel / wall / Field
		Conformity	Generally to BS : 6134 : 1981

Note : For higher ranges, Series 740 / 760 is available with liquid / mercury filled thermal systems.

ORDERING INFORMATION

ENCLOSURE

Pressure die cast Aluminium weatherproof to IP:66. **G M**

Investment cast 316 SS weatherproof to IP:66 with overall size as style GM – for aggressive atmospheres. Fit for offshore. **G A**

Die cast Aluminium flameproof cum weatherproof. CMRS approved to Gr.IIA, IIB & IIC of IS:2148:1981 for flameproofness and IP:66 for weatherproofness. **G K**

MODELS

Remote Mount Types

Series 720 — Vapour Pressure,
Series 770 — Gas filled

Temperature switch with **flexible thermal system** comprising of bulb, semi-rigid stem extension, capillary and armour, having **close fixed non-adjustable** switching differential. **7 2 1**
7 7 1

Same as 721/771, but with auxiliary mechanism permitting **wide adjustable band** of switching differential without disturbing the setpoint (falling temperature). **7 2 3**
7 7 3

A variant of 721/771, employs twin levers each operating a SPCO microswitch actuated by a single thermal system through a unique linkage thereby providing two independent adjustable set points, each with its own setting scale, spring & switch. **7 8 1**
7 7 4

Direct Mount Types

Series 730 only — Vapour Pressure

Similar to 721, but with a **rigid stem thermal system** comprising of bulb and rigid stem. **7 3 1**

Similar to 731, but has a **wide adjustable band** of switching differential. **7 3 3**

A variant of 731, provides two independent adjustable setpoints actuated by a single rigid stem thermal system similar to 781. **7 3 4**

THERMAL SYSTEM DATA

All parts including bellows are of SS except filling tail. **0**

Same as above but with sealed protection for Ammonia environment. **A**

For Series 720 / 730 Bulb 12Ø x 80 Std.
For Series 770 Bulb 12Ø x 140 Std.
For optional bulb sizes and capillary lengths consult factory.

FOR SERIES 720 / 770

3 metre capillary 250 mm semi rigid stem. **E**
3 metre capillary 500 mm semi rigid stem. **F**
6 metre capillary 250 mm semi rigid stem. **G**
6 metre capillary 500 mm semi rigid stem. **H**

FOR 730 SERIES

250 mm Rigid stem (for all ranges **except** Q4K)
400 mm Rigid stem only for Q4K range. **T**

RANGE CODE & AVAILABILITY

RANGE CODE	RANGE Deg. C	MWT Deg. C	721 & 723	731 & 733	781	734	771 & 773	774
B2C	- 25 to +35	45	✓	✓	✓	✓	×	×
J2K	20 to 100	110	✓	✓	✓	✓	×	×
Q4K	90 to 200	210	✓	✓	✓	✓	×	×
U6K	180 to 300	310	✓	×	✓	×	×	×
M1C	- 50 to +150	250	N.A.	N.A.	N.A.	N.A.	✓	✓

SWITCH CODE, RATING & AVAILABILITY (Note 11)

SWITCH CODE (SPCO)	AC RATING	DC RATING IN AMPS						AVAILABILITY OF SPCO IN MODELS	AVAILABILITY OF DPCO IN MODELS
		RESISTIVE			INDUCTIVE				
		220V	110V	24V	220V	110V	24V		
D	15A 250 / 125V	0.2	0.4	2.0	0.02	0.03	1.0	721, 731, 771 781, 734 & 774	721, 731 & 771
3	15A 250 / 125V	N.R.	N.R.	N.R.	N.R.	N.R.	N.R.	721, 731, 771, 773, 781, 734 & 774	721, 731, 771 & 773
4	1A 125V	N.A.	0.5	0.5	N.A.	0.25	0.25	721, 731, 771 781, 734 & 774	721, 731 & 771
5	3A 250V / 5A 125V	0.2	0.4	4.0	0.2	0.4	3.0	721, 731, 771 781, 734 & 774	721, 731 & 771
6	0.1A 125V	N.A.	N.R.	0.1	N.R.	N.R.	N.A.	721, 731, 771 781, 734 & 774	721, 731 & 771
7	N.R.	N.R.	N.R.	1.0	N.R.	N.R.	0.5	721, 731, 771 781, 734 & 774	721, 731 & 771
8	5A 250 / 125V	N.A.	N.A.	5.0	N.A.	N.A.	3.0	721, 731, 771 781, 734 & 774	721, 731 & 771
9	4A 115V 400 Hz.	N.A.	N.A.	4.0	N.A.	N.A.	2.0	721, 731, 771 781, 734 & 774	721, 731 & 771
G	N.R.	N.R.	N.R.	1.0	N.R.	N.R.	0.25	721, 731, 771 781, 734 & 774	721, 731 & 771
E	15A 250 / 125V	0.3	0.75	15.0	0.2	0.4	10.0	721, 731 & 771	721, 731 & 771
F	15A 250 / 125V	0.3	0.75	15.0	0.2	0.4	10.0	721, 731 & 771	721, 731 & 771
S	5A 250 / 125V	0.25	0.5	3.0	0.1	0.2	2.0	721, 731, 771 781, 734 & 774	721, 731 & 771

Codes 3 & D – For General purpose usages.

Code 4 – With Noble metal contact.

Codes 5 – For General purpose with good DC rating.

Code 6 – With Noble metal contact (Low Rating)

Code 7 – Environmentally sealed switch with Gold plated contact.

Code 8 – Environmentally sealed switch with Silver alloy contact.

Code 9 – Hermetically sealed, inert gas filled with Silver alloy contact.

Code G – Hermetically sealed, inert gas filled with Gold plated contact.

Code S – IP:67 sealed microswitch with silver Nickel contact.

Codes E & F – Manual reset switch. Auto change over on rising and falling temperature respectively. Resetting is Manual.

N.A. – Not Available

N.R. – Not Recommended

CAPILLARY AND MOUNTING

The **flexible thermal system** of Models 721, 723, 781, 771, 773 and 774 comprises of 304 SS armoured, 316 SS capillary attached to the 316 SS sensing bulb via 304 SS semi-rigid stem extension, on which a 3/8" NPT(M) compression gland slides to enable various depths of thermowells to be accommodated.

The thermal system of models 731, 733 & 734 comprises a 316 SS **rigid stem** attached to the 316 SS sensing bulb by an extension on which a 3/8" NPT(M) compression gland slides to accommodate various depths of thermowells.

In models 721, 723 & 781 setpoint will be affected by relative position of head and sensing bulb. i.e., sensing bulb 1 metre above / below head will be equal to setpoint shift ±1% of full scale approx.

For models 731, 733 & 734 with **rigid stem** and 771, 773 & 774 this does not apply.

SWITCHING DIFFERENTIAL DATA

TABLE – A : Fixed on-off differentials for style GM/GA – 721/731/771 with 1 SPCO contact switching differentials will be less than or equal to the published values. For style GK multiply the listed differential by 1.5 times.

Model	Range Code	Range Deg. C	On-off Differential in Deg. C			
			Switch Code			
			3, D, 4, 6	5	7, 8, S	9, G
721 / 731	B2C	(-) 25 to +35	4	9	12	12
	J2K	20 to 100	2	6	6	6
	Q4K	90 to 200	3	7	9	9
721	U6K	180 to 300	4	9	12	12
771	M1C	(-) 50 to +150	5.5	14	14	14

TABLE – B : Fixed on-off differentials for style GM/GA – 721/731/771 with 2 SPCO contacts (for DPDT action). Switching differentials will be less than or equal to the published values. For style GK multiply the following differentials by 1.2 times.

Model	Range Code	Range Deg. C	On-off Differential in Deg. C			
			Switch Code			
			33, D D, 44, 66	55	77, 88, S S	99, G G
721 / 731	B2C	(-) 25 to +35	5	12	16	18
	J2K	20 to 100	3	8	8	9
	Q4K	90 to 200	4	9	12	13
721	U6K	180 to 300	5	12	18	18
771	M1C	(-) 50 to +150	8	18	18	18

TABLE – C : Wide band adjustable on-off differentials for style GM/GA –723 / 733 / 773 with SPCO/2SPCO (for DPCO action) contacts. For style GK multiply the lower limit of the listed wide band adjustable differential values by 1.2 times.

Model	Range Code	Range Deg. C	Wideband Adjustable Switching Differential in Deg. C	
			Switch Code	
			3	33
723 / 733	B2C	(-) 25 to +35	10 – 30	12 – 30
	J2K	20 to 100	10 – 30	12 – 30
	Q4K	90 to 200	8 – 30	10 – 30
723	U6K	180 to 300	10 – 30	12 – 30
773	M1C	(-) 50 to +150	30 – 100	40 – 100

For Switching Differential of models 781, 734, 774 and for Manual reset type micro switches, please consult factory.

NOTES

- Gr.IIA & IIB of IS:2148 is equivalent to NEC CL.1, Gr.C & D. Gr.IIC of IS:2148 is equivalent to NEC CL.1, DIV.1, Gr.A & B.
- Style GM/GA is weatherproof only if all entries and joint faces are properly sealed. Style GK is weatherproof only if cover 'O' ring is retained in position and proper FLP cable gland is used. It is recommended to procure cable glands along with GK instruments to avoid neglect of it while installation.
- Intrinsic Safety (Exi) — Temperature Switches are classified as simple electrical apparatus as per BS 5345–6.3.3. Hence Temperature Switches with GM/GA enclosures may be used in intrinsically safe systems without certification if energy levels are limited to 1.2V, 0.1A or 25 mW.
- Accuracy & Repeatability are one and the same for all blind temperature switches.
- The instrument is calibrated in the mounting position depicted in the drawing. Hence mounting in any other direction will cause a minor range shift.
- A Temperature switch is a switching device and not a measuring instrument — eventhough it has a scale to assist setting. For this reason, Test Certificates will not contain individual ON-OFF switching values at different scale readings. Maximum differential obtained alone will be declared, besides other specifications.
- Select working range of the instrument such that the set value lies in the mid 35% of the range i.e., between 35% and 70% of range span.
- For switching differential values please refer respective Range Table. Switching differentials furnished are nominal values under test conditions at mid-scale and will vary with range settings and operating conditions.
- On and off settings should not exceed the upper or lower range span.
- DPCO action is achieved by two SPCO switches synchronised to practical limits i.e., $\pm 2\%$ of FSR. Differential for DPCO contacts are higher than that of SPCO as force required to actuate the contacts are more. Please refer respective range table for exact values.
- Contact life of microswitches are 5×10^5 switching cycles for nominal load. To quench DC sparks, use diode in parallel with inductance, ensuring polarity. A 'R-C' network is also recommended with 'R' value in Ohms equal to coil resistance and 'C' value in micro Farads equal to holding current in Amps.
- All models are suitable for operating within a range of ambient temperature from (-) 10°C to (+) 60°C. Below 0°C, precautions should be taken in humid atmospheres to prevent frost formation inside the instrument from jamming the mechanism.

In models 721, 723 & 781 it is advisable to avoid the condition where the ambient temperature is within $\pm 5^\circ\text{C}$ of the setpoint. Under this condition the liquid / vapour phase becomes less well defined and the switching differential increases. Where this condition is unavoidable refer to models 740/760 liquid expansion temperature switches or 771–4.

In Models 771, 773 & 774 a 10°C rise in ambient temperature will on average result in 1°C fall in setpoint.
- Standard thermowell for all models is 304SS and threaded 1/2" NPTM with immersion length U = 150mm. Other thermowells are also available to order. Ask for drawing.
- Accuracy figures are exclusive of test equipment tolerance on the claimed values.
- All performance data guaranteed $\pm 5\%$.



MOUNTING DIMENSIONS

WEATHERPROOF ENCLOSURE — STYLE 'GM'

MODELS 721, 723, 781, 771, 773 & 774

MODELS 731, 733 & 734

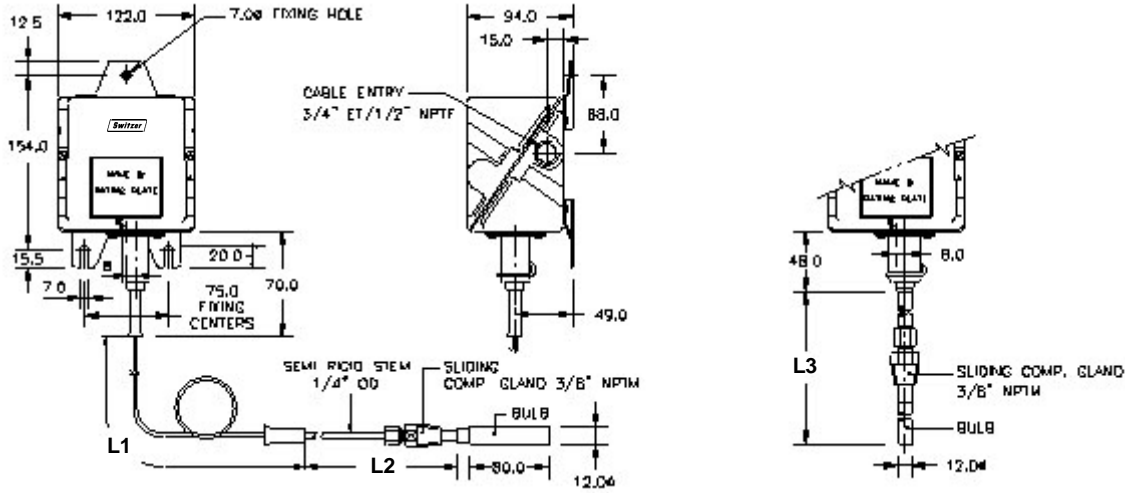

FLAMEPROOF ENCLOSURE — STYLE 'GK'

MODELS 721, 723, 781, 771, 773 & 774

MODELS 731, 733 & 734

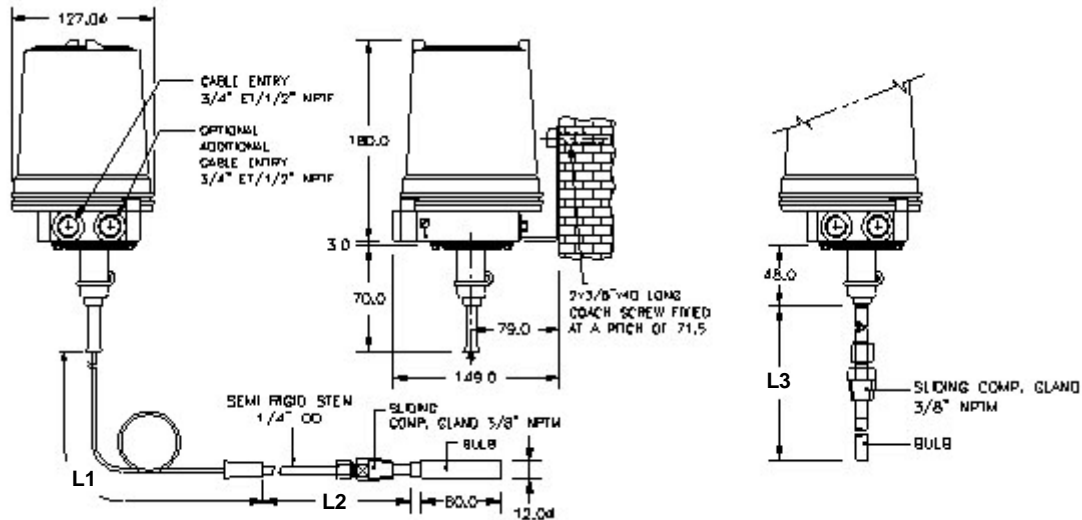

NOTES:

- Dim L1, L2 varies depending on armoured capillary length
- Use certified weatherproof cable gland for GM enclosure
- It is mandatory to use certified flameproof cum weatherproof cable gland for flameproof enclosures.

- L1 — Length of armoured SS capillary 3 Mtrs. or 6 Mtrs.
- L2 — Length of semi rigid stem 250 mm or 500 mm (excludes compression gland length)
- L3 — Length of rigid stem including bulb 250 mm,

All dimensions are in mm

Prior notification of changes in specifications is impracticable due to continuous improvement.

FOR SWITZER'S OFFICES IN INDIA

CHECK AT:

<http://www.switzerinstrument.com/offices.htm>