



DIFFERENTIAL PRESSURE SWITCHES

DIAPHRAGM SENSOR WEATHERPROOF FLAMEPROOF

- VERY LOW RANGES ● CLEAN ROOMS ● FILTER BLOCKAGE ●
- AIR PURGE SYSTEMS ● FAN FAILURE ● FAN EXHAUST ●
- REFRIGERATION COILS ● DRYING OVENS ●



MODEL 310 IN GN ENCLOSURE



MODEL 310 IN GK ENCLOSURE

SWITZER Series 310 differential pressure switches are specially designed for sensing very low differential pressures in mmWC/mbar ranges for reliable setting in varied applications.

A precision contoured synthetic elastomer diaphragm senses low differential pressures applied to either side of it and actuates a snap-acting microswitch when the input differential pressure is slightly above or below the pre-set value.

While Style GN housing offers limited very low ranges and microswitches to meet OEM requirements, Style GM & GK versions offer wider ranges, wideband adj. facility, more microswitch options and flameproofness.

A calibrated scale is provided for approximate switch setting. The switch mechanism and the set point adjustment are external to the sensing chamber and completely isolated from contact with the process medium.

GENERAL SPECIFICATIONS

Enclosure

GN	Die cast Aluminium, weatherproof to IP : 66
GM	Pressure die cast Aluminium, weatherproof to IP : 66
GK	Die cast Aluminium, weatherproof to IP : 66 & flameproof to Gr.IIA, IIB or IIC (Note 1)

Ranges

Refer Table

Sensor

Neoprene Diaphragm std. Nitrile, EPDM & Silicone are optional

Wetted Parts

Aluminum std.

Mounting

Vertical only

Repeatability

± 2 % FSR (Note 4)

Scale Accuracy

± 5 % FSR (Note 6)

Ambient Temp.

- 10°C to + 60°C (Note 12)

Max. Working Pr.

0.5 bar for all ranges

Max. Working Temp.

95°C for Neoprene, 110°C for Nitrile, 130°C for EPDM and 200°C for Silicone (Note 12 & 13)

Switching

Element

Instrument quality snap-acting SPDT (SPCO) microswitch (Note 10)

Differential

Fixed for GN-310 with one SPDT. Fixed or Wideband adj. for GM/GK-310. Refer tables for values

Connection

Process

1/4" NPTF Std., others through Adaptors.

Electrical

For weatherproof enclosure and Gr.IIA & IIB flameproof enclosure – 3/4" ETF std; 1/2" NPTF optional Dual entry on request for GM/GK For Gr.IIC enclosure 1/2" NPTF dual entry is standard

Conformity

Generally to BS:6134:1981

ORDERING MATRIX

ENCLOSURE

Die Cast Aluminium weatherproof to IP : 66. **GN**

Pressure Die Cast Aluminium weatherproof to IP : 66. **GM**

Die Cast Aluminium flameproof cum weatherproof. CMRS approved to Gr. IIA, IIB & IIC of IS:2148 : 1981 for flameproofness and IP :66 for weatherproofness. **GK**

MODEL

This is the basic Differential Pressure Switch meant for low/ultra low range spans having very low non-adjustable fixed switching differential. **3 1 0**

Same as 310 but with auxiliary mechanism providing adjustment of switching differential between 5 to 10% minimum to 60% maximum of FSR (not available in GN enclosure). **3 1 3**

SENSORS & WETTED PARTS

Neoprene diaphragm and cast Aluminium wetted parts. **0 0**

Silicone diaphragm and cast Aluminium wetted parts. **2 0**

EPDM diaphragm and cast Aluminium wetted parts. **3 0**

Nitrile diaphragm and cast Aluminium wetted parts. **4 0**

RANGE CODE & AVAILABILITY

RANGE CODE	RANGE mbar	MWP bar	310		313
			GN	GM/GK	GM/GK
B3D	-2.5 to +2.5	0.5	✓	✓	✓
B3X	0 to 2.5	0.5	X	✓	✓
B5D	0.5 to 5	0.5	✓	✓	✓
B7D	1 to 10	0.5	X	✓	✓
C2D	2.5 to 15	0.5	✓	✓	✓
C5D	2.5 to 25	0.5	✓	✓	✓
D4C	5 to 50	0.5	X	✓	✓
D5C	7.5 to 75	0.5	✓	✓	✓
D8D	10 to 100	0.5	X	✓	✓

SWITCH CODE, RATING & AVAILABILITY (Note 8)

SWITCH CODE (SPCO)	AC RATING	DC RATING IN AMPS						AVAILABILITY OF SPCO IN MODELS		AVAILABILITY OF DPCO IN MODELS
		RESISTIVE			INDUCTIVE			GN	GM / GK	GM / GK
		220V	110V	24V	220V	110V	24V			
2	5A 250 / 125V	0.2	0.3	1.0	0.02	0.03	0.5	N.A.	310	310
D	15A 250 / 125V	0.2	0.4	2.0	0.02	0.03	1.0	310	310	310
3	15A 250 / 125V	N.R.	N.R.	N.R.	N.R.	N.R.	N.R.	310	310	310
4	1A 125V	N.A.	0.5	0.5	N.A.	0.25	0.25	310	310	310
5	5A 250 / 125V	0.2	0.4	4.0	0.2	0.4	3.0	N.A.	313	313
6	0.1A 125V	N.A.	N.R.	0.1	N.R.	N.R.	N.A.	N.A.	310	310
S	5A 250 / 125V	0.25	0.5	3.0	0.1	0.2	2.0	N.A.	310	310
9	4A 115V: 400 HZ	N.A.	N.A.	3.0	N.A.	N.A.	1.0	N.A.	310	310
G	N.R.	N.R.	N.R.	1.0	N.R.	N.R.	0.25	N.A.	310	310

Codes 2, 3, D - For General purpose usages.

Code 4 - Gold Alloy contact.

Codes 5 - For General purpose with good DC rating.

Codes 6 - Noble metal contact (Low Rating)

Code S - IP:67 sealed microswitch with silver Nickel contact.

Code 9 - Hermetically sealed, inert gas filled with Silver alloy contact.

Code G - Hermetically sealed, inert gas filled with Gold plated contact.

PRESSURE CONVERSION TABLE

bar	Kgf / Cm ²	lbf / in ²	atm.	ft H ₂ O	in H ₂ O	m H ₂ O	Cm Hg	In Hg	torr (mm Hg)
1	1.01972	14.5038	0.9869	33.4553	401.463	10.19718	75.0062	29.530	750.062
0.98067	1	14.2233	0.98784	32.808	393.701	10	73.556	28.959	735.56
0.06895	0.07031	1	0.06085	2.307	27.68	0.70307	5.171	2.0360	51.715
1.01325	1.03323	14.6959	1	33.9	406.8	10.3323	76.0	29.9213	760
0.02989	0.03048	0.4335	0.02949	1	12	0.3048	2.242	0.8827	22.42
0.00249	0.00254	0.0361	0.00246	0.0833	1	0.0254	0.187	0.0734	1.87
0.09807	0.1	1.422	0.0968	3.281	39.37	1	7.3556	2.896	73.356
0.01333	0.0136	0.1934	0.0132	0.4461	5.353	0.13595	1	0.3937	10
0.03386	0.03453	0.4911	0.03342	1.133	13.595	0.3453	2.54	1	25.4
0.00133	0.00136	0.01934	0.00132	0.04461	0.5353	0.0136	0.1	0.03937	1

SWITCHING DIFFERENTIAL DATA FOR MICROSWITCH CODES '2', '3', 'D', '4' & '5'

TABLE – A : MODEL GN 310 — FIXED DIFFERENTIAL

Range Code	Range mbar	On-off Differentials in mbar	
		GN 310	
		3/D	4
B3D	± 2.5	0.5 +Ve 0.8 -Ve	0.5 +Ve 0.8 -Ve
B5D	0.5 – 5	0.8	0.4
C2D	2.5 – 15	1.0	0.5
C5D	2.5 – 25	1.0	0.5
D5C	7.5 – 75	5.0	2.5
DPCO not possible			

TABLE – B : MODEL GM / GK 313 — WIDEBAND DIFFERENTIAL

Range Code	Range mbar	On-off Differentials in mbar	
		GM 313	GK 313
		5	5
B3X	0 – 2.5	x	x
B5D	0.5 – 5	1.1 – 3	1.8 – 3
B7D	1 – 10	1.1 – 6	1.8 – 6
C2D	2.5 – 15	1.2 – 9	2.0 – 9
C5D	2.5 – 25	1.2 – 15	2.0 – 15
D4C	5 – 50	1.8 – 30	3.0 – 30
D5C	7.5 – 75	2.4 – 45	4.0 – 45
D8D	10 – 100	2.7 – 60	4.4 – 60

TABLE – C : MODEL GM / GK 310 — FIXED DIFFERENTIAL

Range Code	Range mbar	On-off Differentials in mbar							
		GM 310				GK 310			
		2	3 / D	4	5	2	3 / D	4	5
B3D	± 2.5	x	0.9 -Ve 0.7 +Ve	0.9 -Ve 0.7 +Ve	x	x	1.6 -Ve 1.1 +Ve	1.6 -Ve 1.1 +Ve	x
B3X	0 – 2.5	0.6	0.4	0.6	0.7	1.0	0.7	1.1	1.3
B5D	0.5 – 5	0.8	0.6	0.8	0.9	1.4	1.1	1.4	1.6
B7D	1 – 10	0.8	0.6	0.8	0.9	1.5	1.2	1.6	1.6
C2D	2.5 – 15	1.5	0.8	1.0	1.3	2.7	1.4	1.8	2.3
C5D	2.5 – 25	1.6	0.9	1.2	1.5	2.7	1.6	2.1	2.7
D4C	5 – 50	3.0	1.3	1.5	2.2	5.4	2.3	2.7	3.9
D5C	7.5 – 75	3.2	1.5	1.7	2.5	5.8	2.7	3.0	4.5
D8D	10 – 100	3.5	2.0	2.2	2.8	6.3	3.6	3.9	5.0

For on-off differentials of other switch codes '6', 'S', '9' & 'G' consult factory.

To arrive at deadband for DPCO switching, apply a multiplication factor of 1.3 to the above differential values for GM & GK. DPCO not available in Model GN 310.

NOTES

- Gr.IIA & IIB of IS:2148 is equivalent to NEC CL.1, Gr.C & D. Gr.IIC of IS:2148 is equivalent to NEC CL.1, DIV.1, Gr.A & B.
- Style GM/ GN is weatherproof only if all entries and joint faces are properly sealed. Style GK is weatherproof only if cover 'O' ring is retained in position and proper FLP cable gland is used. It is recommended to procure cable glands along with GK instruments to avoid neglect of it while installation.
- Intrinsic Safety (Exi) — Differential Pressure Switches are classified as simple electrical apparatus as per BS 5345–6.3.3. Hence Differential Pressure Switches with GM/ GN enclosures may be used in intrinsically safe systems without certification if energy levels are limited to 1.2V, 0.1A or 25 mW.
- Accuracy & Repeatability are one and the same for all blind differential pressure switches. A shift of ±2% may be observed in setpoint when pressure falls from full static pressure. Settings will also shift with varying temperature.
- The instrument is calibrated in the mounting position depicted in the drawing. Hence mounting in any other direction will cause a minor range shift, especially in low and compound ranges.
- A differential pressure switch is a switching device and not a measuring instrument — eventhough it has a scale to assist setting. For this reason, Test Certificates will not contain individual ON-OFF switching values at different scale readings. Maximum differential obtained alone will be declared, besides other specifications.
- Select working range of the instrument such that the set value lies in the mid 35% of the range i.e., between 35% and 70% of range span.
- For switching differential values please refer respective Range Table. Switching differentials furnished are nominal values under test conditions at mid-scale and will vary with range settings and operating conditions.
- On and off settings should not exceed the upper or lower range span.
- DPCO action is achieved by two SPCO switches synchronised to practical limits i.e., ±2% of FSR. Deadband for DPCO contacts are higher than that of SPCO as force required to actuate the contacts are more.
- Contact life of microswitches are 5×10^5 switching cycles for nominal load. To quench DC sparks, use diode in parallel with inductance, ensuring polarity. A 'R-C' network is also recommended with 'R' value in Ohms equal to coil resistance and 'C' value in micro Farads equal to holding current in Amps.
- Ambient temperature range: All models are suitable for operating within a range of ambient temperature from (–) 10°C to (+) 60°C provided the process does not freeze within this range. Below 0°C, precautions should be taken in humid atmospheres to prevent frost formation inside the instrument from jamming the mechanism. Occasional excursions beyond this range are possible but accuracy might be impaired. The microswitch is the limiting factor which should never exceed the limits (–) 25°C to (+) 80°C.
- Fluid Temperature: A differential pressure switch connected to the main pipe is not subjected to the flow and therefore is not fully exposed to the fluid temperature. Use of adequate length of impulse piping will greatly reduce excessive heating of the sensing element. For e.g., connection of 7.5 cm of 12 mm dia impulse piping will reduce water temperature of 100°C to 65°C at an ambient temperature of 50°C. Ask factory for piping nomogram for different temperatures.
- Ensure that impulse pipework applies no stress on sensing element housing and use spanners to hold pressure port / housing when connections are made.
- Accuracy figures are exclusive of test equipment tolerance on the claimed values.**
- All performance data guaranteed ±5%.**

MOUNTING DIMENSIONS

GM – 310 / 313

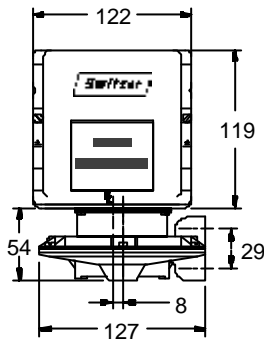

Cable Entry
3/4" ET /
1/2" NPTF

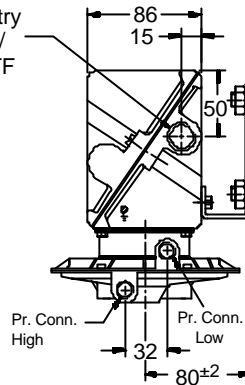

Alternate Horizontal
Position of 2" Ø Pipe
(Fix 'U' Bolt Vertically)
2" Pipe by Customer

3/8" BSW 'U' Bolt 2 Nos.
Fixed at a Pitch of 71.5 Sq
(4 Nos. 10.5Ø Fixing Holes)

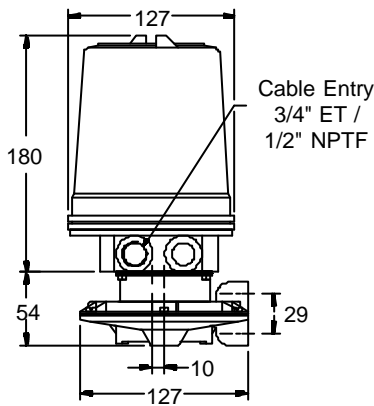

Cable Entry
3/4" ET /
1/2" NPTF

GK – 310 / 313

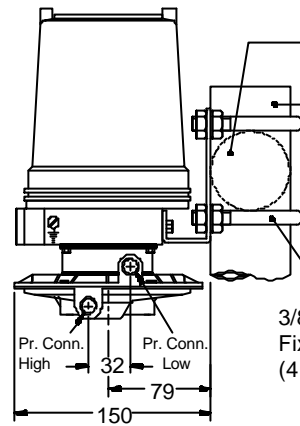

Alternate Horizontal
Position of 2" Ø Pipe
(Fix 'U' Bolt Vertically)
2" Pipe by Customer

3/8" BSW 'U' Bolt 2 Nos.
Fixed at a Pitch of 71.5 Sq
(4 Nos. 10.5Ø Fixing Holes)

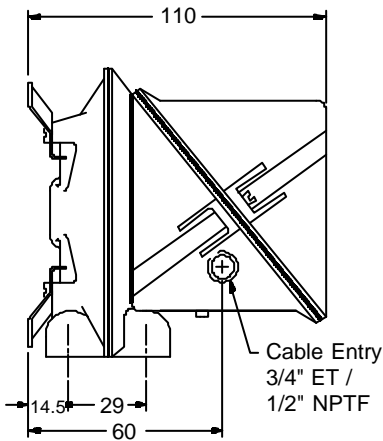

Cable Entry
3/4" ET /
1/2" NPTF

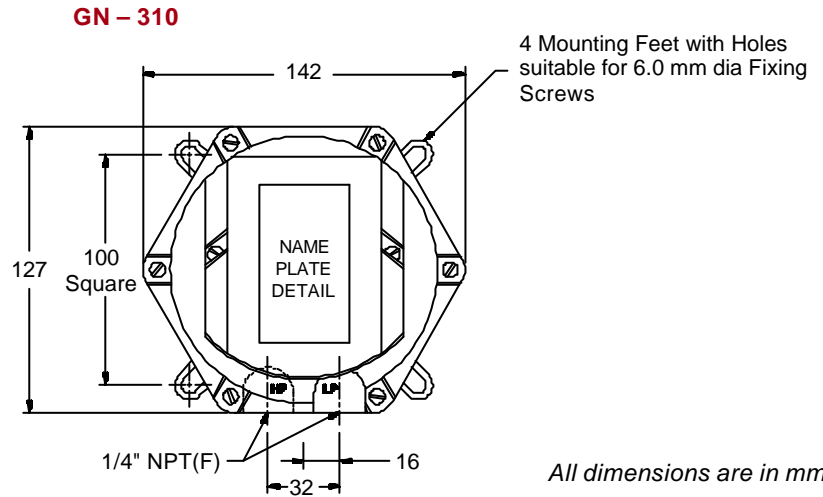

4 Mounting Feet with Holes
suitable for 6.0 mm dia Fixing
Screws

All dimensions are in mm

Prior notification of changes in specification is impracticable due to continuous improvement.

FOR **SWITZER'S** OFFICES IN INDIA

CHECK AT:

<http://www.switzerinstrument.com/offices.htm>