



PRESSURE SWITCHES

**DIAPHRAGM SENSOR
WEATHERPROOF
FLAMEPROOF**

SERIES 020

- **VERY LOW RANGES** ● **VACUUM PICK-UPS** ●
- **AIR PURGE SYSTEMS** ● **DRYING OVENS** ●



Model 020 in GM Weatherproof Enclosure



Model 020 in GK Flameproof Enclosure

SWITZER Series 020 pressure switches are specially designed for very low input pressure from mmWC and upto 4 bar for use in varied applications. Switzer's time proven Series 200 mechanisms are employed to ensure reliable switching.

A precision contoured synthetic elastomer diaphragm senses low pressures applied to it and actuates a snap-acting microswitch when the input pressure is above or below the pre-set value.

The instrument is available both in weatherproof and flameproof housings. Enclosures, sensing element materials, microswitches and switching modes can be combined to offer the variety needed to suit the demands of ever expanding industrial processes.

Setpoint is continuously adjustable over the instrument range and can be set precisely against a master gauge. A scale is provided for approximate switch setting.

GENERAL SPECIFICATIONS

Enclosure		Ambient Temp.	- 10°C to + 60°C (Note 12)
GM	Aluminium pressure die cast weatherproof to IP:66	Max. Working Pr.	Refer Range Table
GA	304SS / 316SS, investment cast, weatherproof to IP:66	Max. Working Temp.	95°C for Neoprene 110°C for Nitrile 130°C for EPDM 200°C for Silicone (Note 13)
GK	Aluminium die cast weatherproof to IP:66 & flameproof to Gr.IIA, IIB or IIC (Note 1)	Switching	
Ranges	Refer Table	Element	Instrument quality snap acting SPDT microswitch
Sensor	Neoprene Diaphragm Std. Nitrile, EPDM & Silicone are optional. Nitrile Diaphragm standard for range codes F1D, A5K, G8B & A6K. Options not available.	Differential	Fixed, Wideband adj. For values refer Tables
Wetted Parts	Aluminum standard. 304 / 316 SS optional	Connection	
Mounting	Vertical only (Note 5)	Process	1/4" NPTF Std., Others through Adaptor. 1/2" NPTF direct only for SS wetted parts.
Repeatability	±2 % FSR (Note 4)	Electrical	3/4" ETF std; 1/2" NPTF optional. Dual entry on request
Scale Accuracy	±5 % FSR (Note 6)	Conformity	Generally to BS:6134 : 1991

ORDERING MATRIX

ENCLOSURE

Aluminium pressure die cast weatherproof to IP:66 with Nitrile gasket. _____ **GM**

304 / 316 SS Investment cast weatherproof to IP:66 with overall size as style GM — for aggressive atmospheres. Fit for offshore. _____ **GA**

Aluminium die cast flameproof cum weatherproof. CIMFR approved to Gr.IIA, IIB & IIC of IS:2148:2004 for flameproofness and IP:66 for weatherproofness _____ **GK**

MODEL

Basic Pressure Switch meant for low/ultra low range spans having very low non-adjustable fixed switching differential. _____ **021**

Same as 021 but with auxiliary mechanism providing adjustment of switching differential between 5 to 10% min and 60% of max. FSR — **023**

MATERIALS OF WETTED PARTS

Neoprene diaphragm and cast Aluminium wetted parts _____ **N5**

Neoprene diaphragm and 304 SS wetted parts — **N4**

Neoprene diaphragm and 316 SS wetted Parts — **N2**

Silicone diaphragm and cast Aluminium wetted parts _____ **S5**

Silicone diaphragm and 304 SS wetted parts — **S4**

Silicone diaphragm and 316 SS wetted Parts — **S2**

EPDM diaphragm and cast Aluminium wetted parts _____ **E5**

EPDM diaphragm and 304 SS wetted parts — **E4**

EPDM diaphragm and 316 SS wetted parts — **E2**

Nitrile diaphragm and cast Aluminium wetted parts _____ **B5**

Nitrile diaphragm and 304 SS wetted parts — **B4**

Nitrile diaphragm and 316 SS wetted parts — **B2**

(Note : F1D, A5K, G8B & A6K ranges are available only with Nitrile diaphragm)

RANGE CODE : Refer Table-1 _____

SWITCH CODE AND RATING : Refer Table-2 _____

ELECTRICAL ENTRY CODE : Refer Table-3 _____

Table 3 : ELECTRICAL ENTRY CODE

Size *	Single Entry		Dual Entry	
	GM/GA	GK	GM/GA	GK
3/4" ETF	A	A	M	M
1/2" NPTF	B	B	N	N
3/4" NPTF	C	---	O	---
M20 x 1.5 **	D	D	P	P
M16 x 1.5	E	---	Q	---
Through Connector				
3 pin plug	2	---	---	---
7 pin plug	3	---	---	---
9 pin plug	4	---	---	---
* Cable gland available on request.				
** Cable Entry is optional. Available on request.				

Table-1 : RANGE CODE & AVAILABILITY

RANGE CODE	RANGE	MWP	021	023
B3X	0 to 2.5 mbar	0.5	✓	✗
B5D	0.5 to 5 mbar	0.5	✓	✓
B7D	1 to 10 mbar	0.5	✓	✓
C2D	2.5 to 15 mbar	0.5	✓	✓
D3B	2.5 to 25 mbar	0.5	✓	✓
D4C	5 to 50 mbar	0.5	✓	✓
D5C	7.5 to 75 mbar	0.5	✓	✓
D8D	10 to 100 mbar	0.5	✓	✓
F1D	40 to 400 mbar	1	✓	✓
A5K	0.2 to 1 bar	4	✓	✓
G8B	0.16 to 1.6 bar	4	✓	✓
A6K	0.4 to 4 bar	7	✓	✓
B5X	-5 to 0 mbar	0.5	✓	✓
B7X	-10 to 0 mbar	0.5	✓	✓
C2X	-20 to 0 mbar	0.5	✓	✓
C5X	-25 to 0 mbar	0.5	✓	✓
X5K	-50 to 0 mbar	0.5	✓	✓
X8K	-100 to 0 mbar	0.5	✓	✓
B3D	-2.5 to +2.5 mbar	0.5	✓	✗
XB7	-10 to +10 mbar	0.5	✓	✓
X9K	-20 to +20 mbar	0.5	✓	✓
D4X	-50 to +50 mbar	0.5	✓	✓

Table-2 : SWITCH CODE, RATING & AVAILABILITY (Note 10)

SWITCH CODE (SPDT)	AC RATING	DC RATING IN AMPS						AVAILABILITY OF	
		RESISTIVE			INDUCTIVE			SPDT IN MODELS	DPDT IN MODELS
		220V	110V	24V	220V	110V	24V		
2*	5A 250 / 125V	0.25	0.5	5.0	0.1	0.25	3.0	021	021
D	15A 250 / 125V	0.2	0.4	2.0	0.02	0.03	1.0	021	021
3	15A 250 / 125V	N.R.	N.R.	N.R.	N.R.	N.R.	N.R.	021	021
W	15A 250 / 125V	0.3	0.5	6.0	0.05	0.1	4.0	023	023
4	1A 125V	N.A.	0.5	0.5	N.A.	0.25	0.25	021	021
5	5A 250 / 125V	0.2	0.4	4.0	0.2	0.4	3.0	021	021
6	0.1A 125V	N.R.	N.R.	0.1	N.R.	N.R.	N.A.	021	021
J	5A 250V	N.A.	N.A.	5.0	N.A.	N.A.	3.0	021	021
K	1A 125V	N.A.	N.A.	1.0	N.A.	N.A.	0.5	021	021
S	5A 250 / 125V	0.25	0.5	3.0	0.1	0.2	2.0	021	021
Codes 2, 3, D & W – For General purpose usages.				Code J – Hermetically sealed, inert gas filled with Silver alloy contact.					
Code 4 – Gold Alloy contact.				Code K – Hermetically sealed, inert gas filled with Silver Gold plated contact.					
Code 5 – For General purpose with good DC rating.				Code S – IP:67 sealed microswitch with silver Nickel contact.					
Code 6 – Gold Alloy contact (Low Rating)				* For Code '2' Microswitch DPDT option available in selected ranges only – Consult factory					
For DPDT, change switch code to "22", "33", etc., while ordering									

N.A. - Not Available N.R. - Not Recommended

SWITCHING DIFFERENTIAL DATA FOR INSTRUMENTS IN GM/GA ENCLOSURE

RANGE CODE	POSITIVE RANGE	ON-OFF DIFFERENTIAL IN mbar — GM / GA ENCLOSURES				
		MODEL 021				MODEL 023
		2	3 / D / 6	4	5	W
B3X	0 to 2.5 mbar	x	0.4	0.6	0.6	x
B5D	0.5 to 5 mbar	0.8	0.6	0.8	0.9	1.7 to 3
B7D	1 to 10 mbar	0.8	0.6	0.8	0.9	1.9 to 6
C2D	2.5 to 15 mbar	0.9	0.7	0.9	1.2	2.0 to 9
D3B	2.5 to 25 mbar	1.0	0.8	1.0	1.3	2.3 to 15
D4C	5 to 50 mbar	1.6	1.1	1.3	2.0	2.8 to 30
D5C	7.5 to 75 mbar	1.8	1.3	1.4	2.2	3.2 to 45
D8D	10 to 100 mbar	2.0	1.5	1.5	2.4	4.0 to 60
F1D	40 to 400 mbar	15.0	20.0	10.0	18.0	30 to 240
A5K	0.2 to 1 bar	50.0	25.0	25.0	50.0	75 to 600
G8B	0.16 to 1.6 bar	60.0	35.0	35.0	50.0	75 to 960
A6K	0.4 to 4 bar	80.0	50.0	50.0	75.0	160 to 2400

Range Code	Negative Range	On-Off Differential in mbar — GM / GA Enclosures			
		Model 021			Model 023
		3/D/6	4	5	W
B5X	-5 to 0 mbar	0.6	0.7	1.1	2.2 to 3.0
B7X	-10 to 0 mbar	0.9	1.0	1.5	2.2 to 6.0
C2X	-20 to 0 mbar	1.1	1.2	2.3	2.6 to 12.0
C5X	-25 to 0 mbar	1.5	1.6	2.5	3.2 to 15.0
X5K	-50 to 0 mbar	2.0	2.2	3.0	5.5 to 30.0
X8K	-100 to 0 mbar	2.5	2.8	3.5	7.5 to 50.0

Range Code	Compound Range mbar	On-Off Differential in mbar — GM / GA Enclosures			
		Model 021			Model 023
		3/D/6	4	5	W
B3D	-2.5 to +2.5	-0.8 / +0.6	-0.9 / +0.5	-1.0 / +0.6	x
XB7	-10 to +10	-1.1 / +0.6	-1.3 / +0.8	-1.5 / +0.8	3.2 to 10
X9K	-20 to +20	-1.5 / +0.8	-1.7 / +1.0	-2.0 / +1.0	3.2 to 20
D4X	-50 to +50	-2.0 / +1.1	-2.2 / +1.3	-3.0 / +1.5	5.7 to 50

SWITCHING DIFFERENTIAL DATA FOR INSTRUMENTS IN GK ENCLOSURE

RANGE CODE	POSITIVE RANGE	ON-OFF DIFFERENTIAL IN mbar — GK ENCLOSURES				
		MODEL 021				MODEL 023
		2	3 / D / 6	4	5	W
B3X	0 to 2.5 mbar	x	0.7	1.1	1.1	x
B5D	0.5 to 5 mbar	1.4	1.1	1.4	1.6	2.4 to 3
B7D	1 to 10 mbar	1.4	1.1	1.4	1.6	2.6 to 6
C2D	2.5 to 15 mbar	1.6	1.3	1.6	2.1	2.7 to 9
D3B	2.5 to 25 mbar	1.8	1.4	1.8	2.3	3.0 to 15
D4C	5 to 50 mbar	2.9	2.0	2.3	3.6	3.5 to 30
D5C	7.5 to 75 mbar	3.2	2.3	2.5	3.9	3.9 to 45
D8D	10 to 100 mbar	3.6	2.7	2.7	4.3	4.7 to 60
F1D	40 to 400 mbar	27.0	18.0	18.0	32.0	40 to 240
A5K	0.2 to 1 bar	90.0	45.0	45.0	90.0	85 to 600
G8B	0.16 to 1.6 bar	108.0	63.0	63.0	90.0	85 to 960
A6K	0.4 to 4 bar	144.0	90.0	90.0	135.0	175 to 2400

Range Code	Negative Range	On-Off Differential in mbar — GK Enclosures			
		Model 021			Model 023
		3/D/6	4	5	W
B5X	-5 to 0 mbar	1.1	1.3	2.0	2.9 to 3.0
B7X	-10 to 0 mbar	1.6	1.8	2.7	2.9 to 6.0
C2X	-20 to 0 mbar	2.0	2.1	4.1	3.2 to 12.0
C5X	-25 to 0 mbar	2.7	2.9	4.5	3.9 to 15.0
X5K	-50 to 0 mbar	3.6	3.9	5.4	6.2 to 30.0
X8K	-100 to 0 mbar	4.5	5.0	6.3	8.2 to 50.0

Range Code	Compound Range mbar	On-Off Differential in mbar — GK Enclosures			
		Model 021			Model 023
		3/D/6	4	5	W
B3D	-2.5 to +2.5	-1.4 / +0.7	-1.6 / +0.9	-1.8 / +1.1	x
XB7	-10 to +10	-2.0 / +1.1	-2.3 / +1.4	-2.7 / +1.4	3.9 to 10
X9K	-20 to +20	-2.7 / +1.4	-3.0 / +1.8	-3.6 / +1.8	3.9 to 10
D4X	-50 to +50	-3.6 / +2.0	-3.9 / +2.3	-5.4 / +2.7	6.4 to 50

- Notes :**
1. For on-off differential values with switch codes 'S', 'J' & 'K' consult factory.
 2. To arrive at differentials for DPDT switching, apply multiplication factor of 1.2 to the above values.

NOTES

- Gr.IIA & IIB of IS:2148 is equivalent to NEC CL.1, Gr.C & D. Gr.IIC of IS:2148 is equivalent to NEC CL.1, DIV.1, Gr.A & B.
- Style GM/GA is weatherproof only if all entries and joint faces are properly sealed. Style GK is weatherproof only if cover 'O' ring is retained in position and flameproof only if proper FLP cable gland is used. It is recommended to procure cable glands along with GK instruments to avoid neglect of it while installation.
- Intrinsic Safety (Exi) — Pressure switches are classified as simple apparatus as they neither generate nor store energy. Hence pressure switches in weatherproof (GM/GA) enclosures also may be used in intrinsically safe systems without certification provided the power source is certified Intrinsic Safe. Because of the low voltages and currents it is recommended to use gold contact and / or sealed contacts.
- Accuracy & Repeatability are not different for all blind pressure switches. A shift of $\pm 2\%$ may be observed in setpoint when pressure falls from full static pressure. Settings will also shift with varying temperature.
- The instrument is calibrated in the mounting position depicted in the drawing. Mounting in any other direction will cause a minor range shift, especially in low and compound ranges. Ranges above 1 bar will not experience this shift.
- A pressure switch is a switching device and not a measuring instrument — even though it has a scale to assist setting. For this reason, Test Certificates will not contain individual ON-OFF switching values at different scale readings. Maximum differential obtained alone will be declared, besides other specifications.
- Select working range of the instrument such that the set value lies in the mid 35% of the range i.e., between 35% and 70% of range span.
- For switching differential values please refer respective Differential Table. Switching differentials furnished are nominal values under test conditions at mid-scale and will vary with range settings and operating conditions.
- On and off settings should not exceed the upper or lower range value.
- DPDT action is achieved by two SPDT switches synchronised to practical limits i.e., $\pm 2\%$ of FSR. Deadband for DPDT contacts are higher than that of SPDT as force required to actuate the contacts are more. Please refer respective differential table for exact values.
- Contact life of microswitches are 5×10^5 switching cycles for nominal load. To quench DC sparks, use diode in parallel with inductance, ensuring polarity. A 'R-C' network is also recommended with 'R' value in Ohms equal to coil resistance and 'C' value in micro Farads equal to holding current in Amps.
- Ambient temperature range: All models are suitable for operating within a range of ambient temperature from (-) 10°C to (+) 60°C provided the process does not freeze within this range. Below 0°C , precautions should be taken in humid atmospheres to prevent frost formation inside the instrument from jamming the mechanism. Occasional excursions beyond this range are possible but accuracy might be impaired. The microswitch is the limiting factor which should never exceed the limits (-) 25°C to (+) 80°C .
- Fluid Temperature: A pressure switch when connected to the process is not subjected to through flow and therefore is not fully exposed to the fluid temperature. Use of adequate length of impulse piping will greatly reduce excessive heating of the sensing element. For e.g., connection of 7.5 cm of 12 mm dia impulse piping will reduce water temperature of 100°C to 65°C at an ambient temperature of 50°C . Ask factory for piping nomogram # 441184-4 for different temperatures.
- Ensure that impulse pipework applies no stress on sensing element housing and use spanners to hold pressure port/housing when connections are made.
- Custom built instruments are available for special service requirements under Special Engineering Category.
- Accuracy figures are exclusive of test equipment tolerance on the claimed values.**
- All performance data are guaranteed to $\pm 5\%$.**

MOUNTING DIMENSIONS

'GM' ENCLOSURE

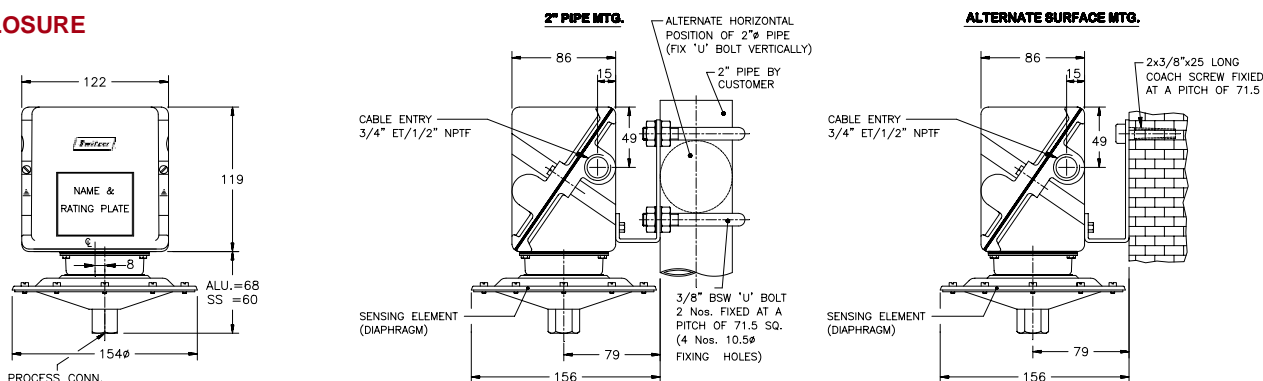

'GK' ENCLOSURE

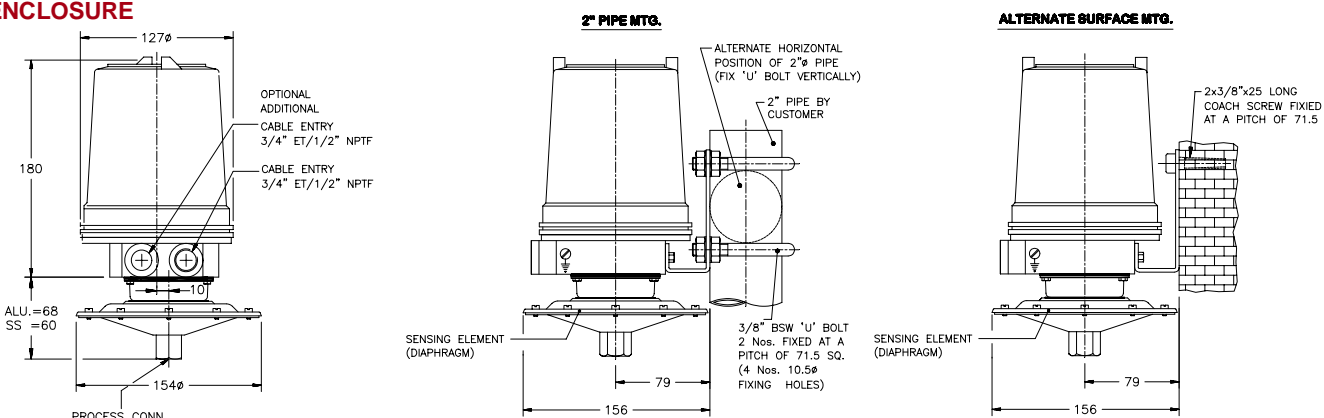

All dimensions are in mm

Prior notification of changes in specification is impracticable due to continuous Improvement

FOR SWITZER'S OFFICES IN INDIA

CHECK AT:

<http://www.switzerinstrument.com/offices.htm>